

---

# **Machine Learning**

Neural Networks

# Human Brain

---

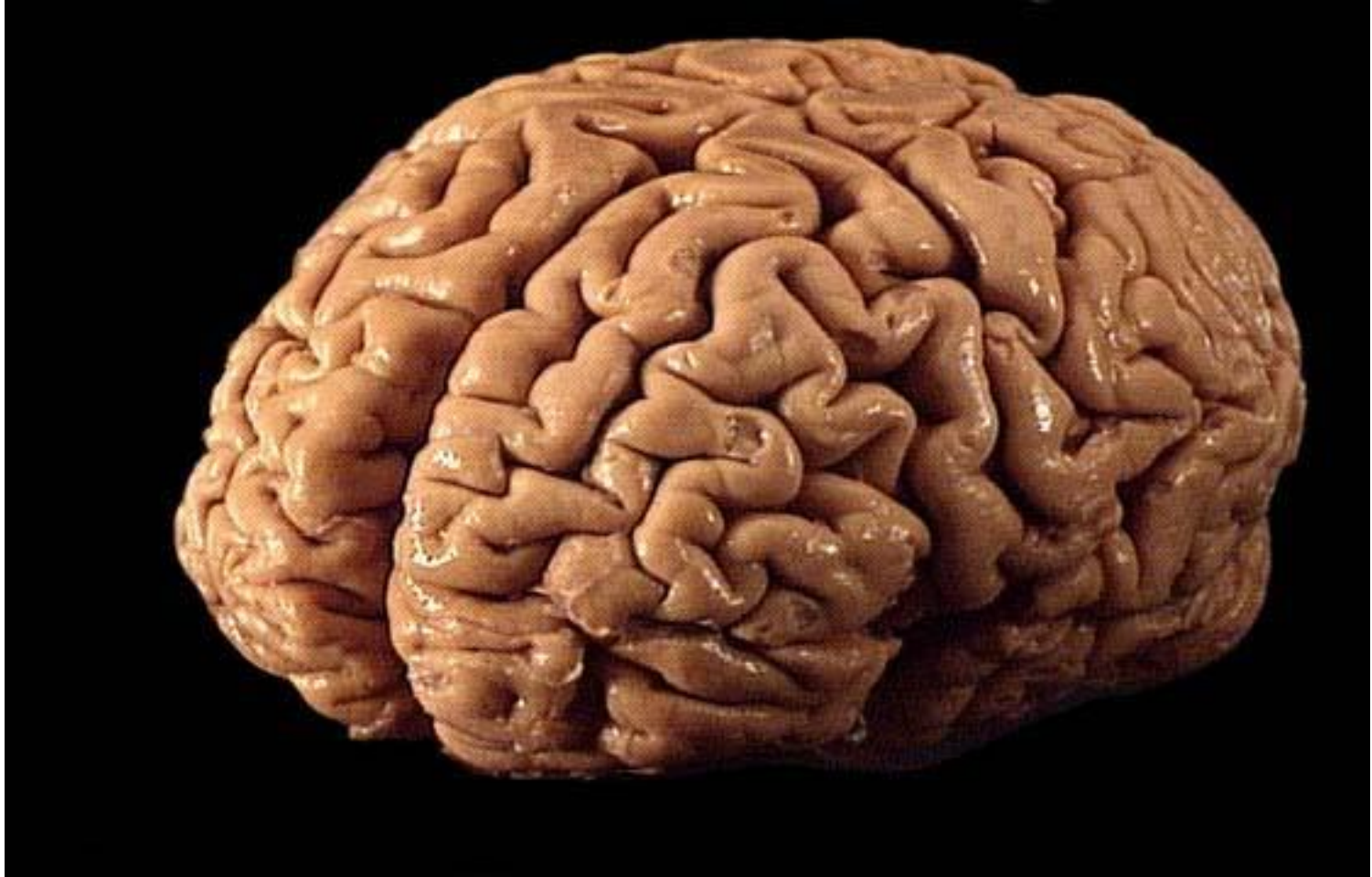

# Neurons

---

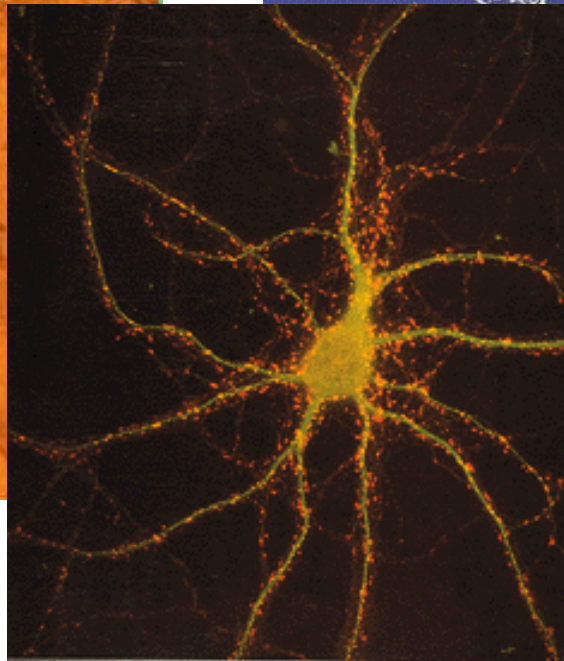
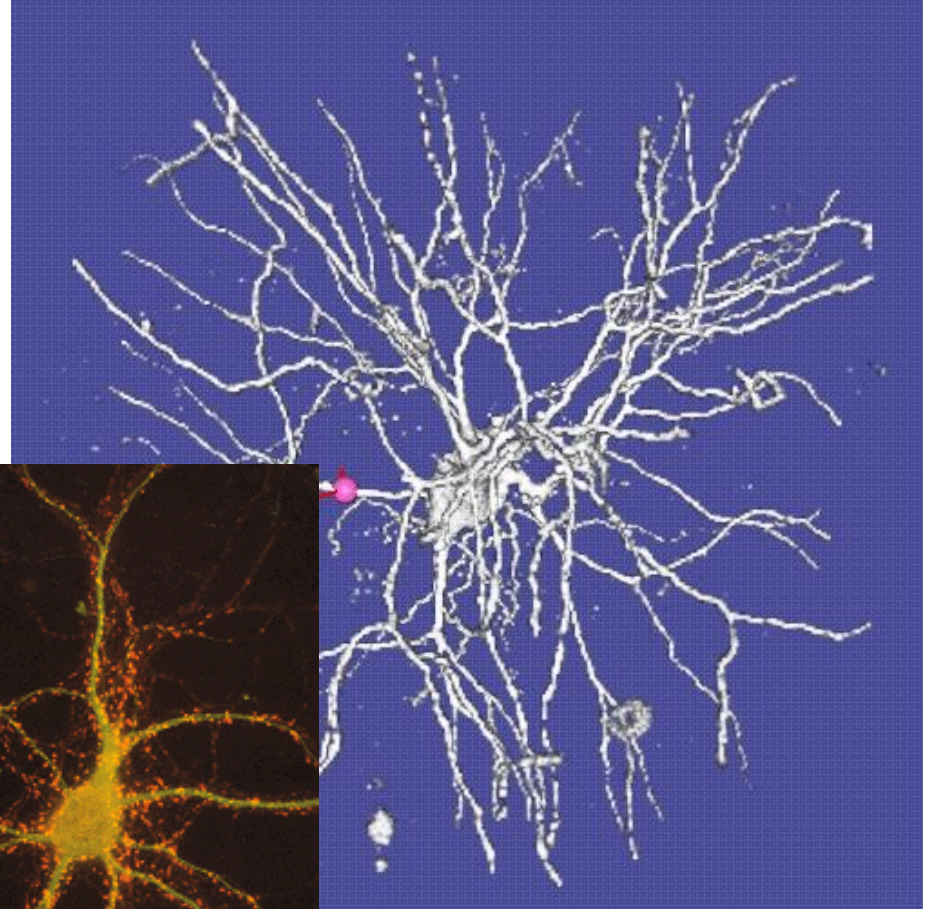
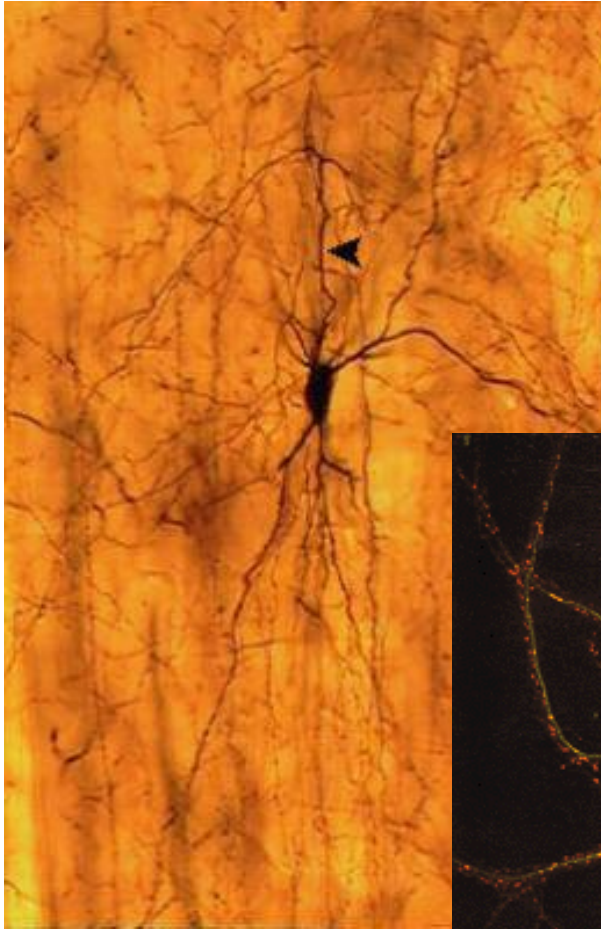

# Input-Output Transformation

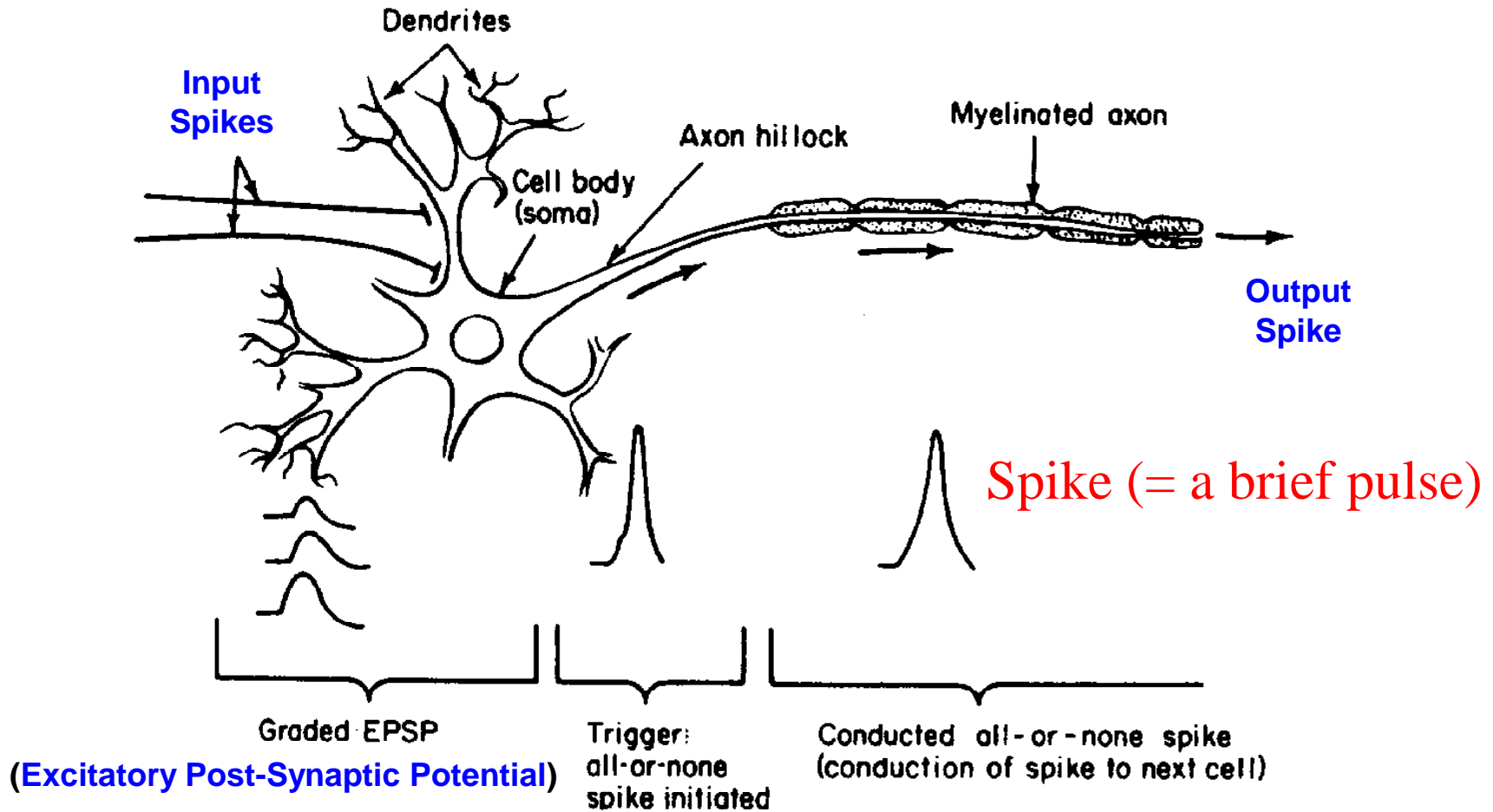

# Human Learning

---

- Number of neurons:  $\sim 10^{11}$
- Connections per neuron:  $\sim 10^4$  to  $10^5$
- Neuron switching time:  $\sim 0.001$  second
- Scene recognition time:  $\sim 0.1$  second

100 inference steps doesn't seem much

# Machine Learning Abstraction

---

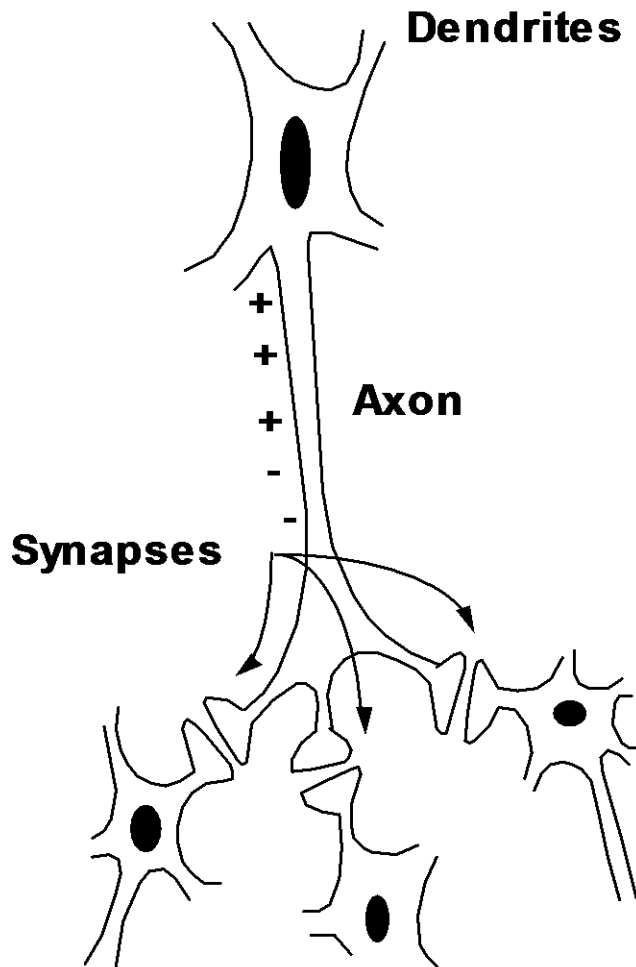

Impulse  
↓

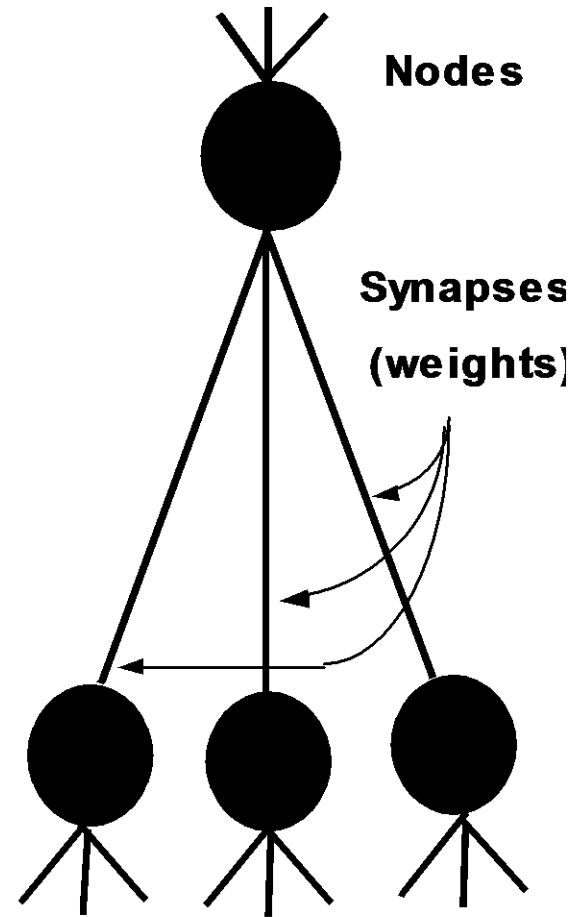

# Artificial Neural Networks

---

- Typically, machine learning ANNs are **very** artificial, ignoring:
  - Time
  - Space
  - Biological learning processes
- More realistic neural models exist
  - Hodgkin & Huxley (1952) won a Nobel prize for theirs (in 1963)
- Nonetheless, very artificial ANNs have been useful in many ML applications

# Perceptrons

---

- The “first wave” in neural networks
- Big in the 1960's
  - McCulloch & Pitts (1943), Woodrow & Hoff (1960), Rosenblatt (1962)

# Perceptrons

---

- Problem def:
  - Let  $f$  be a target function from  $X = \langle x_1, x_2, \dots \rangle$  where  $x_i \in \{0, 1\}$  to  $y \in \{0, 1\}$
  - Given training data  $\{(X_1, y_1), (X_2, y_2), \dots\}$ 
    - Learn  $h(X)$ , an approximation of  $f(X)$

# A single perceptron

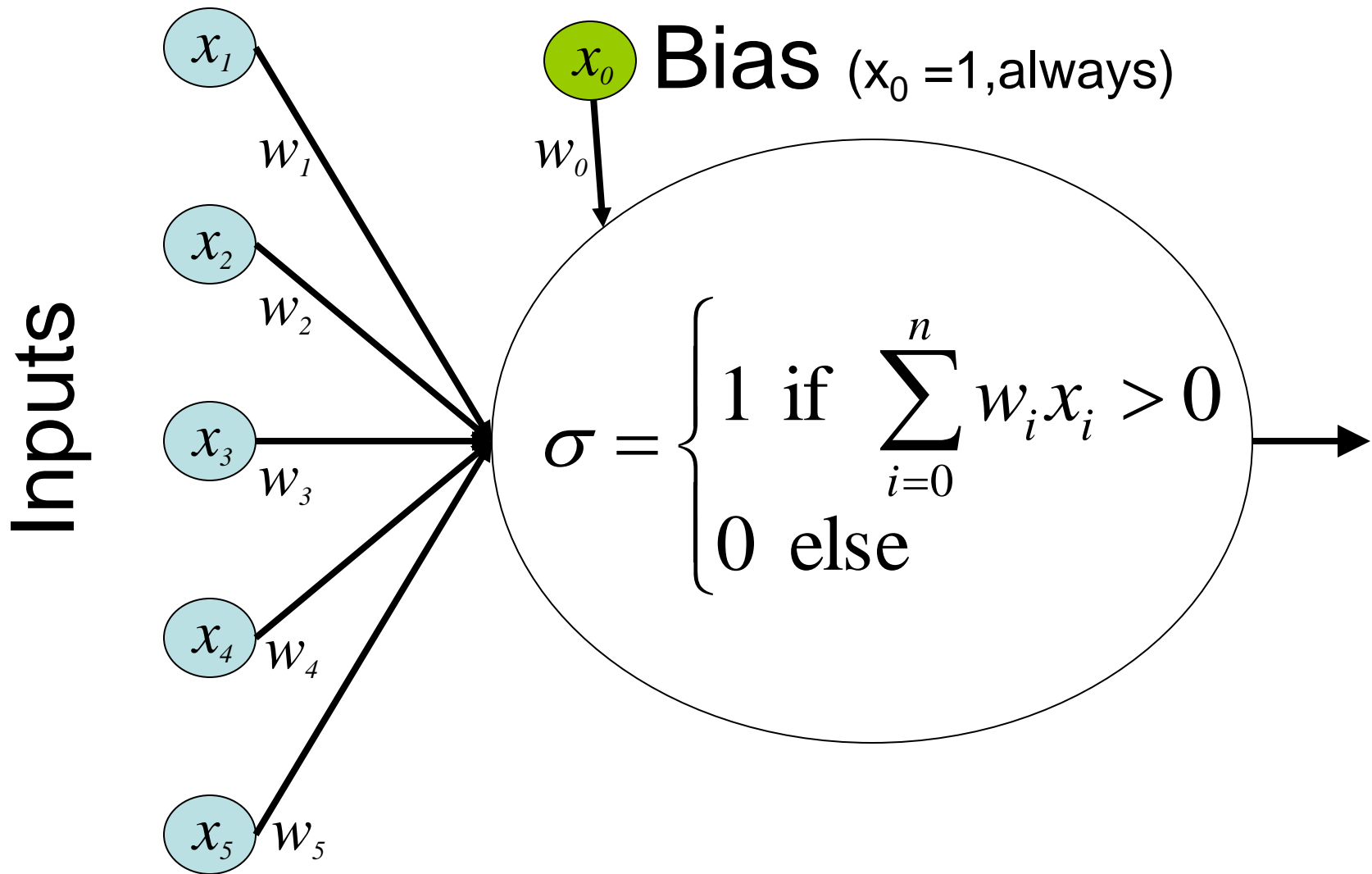

# Logical Operators

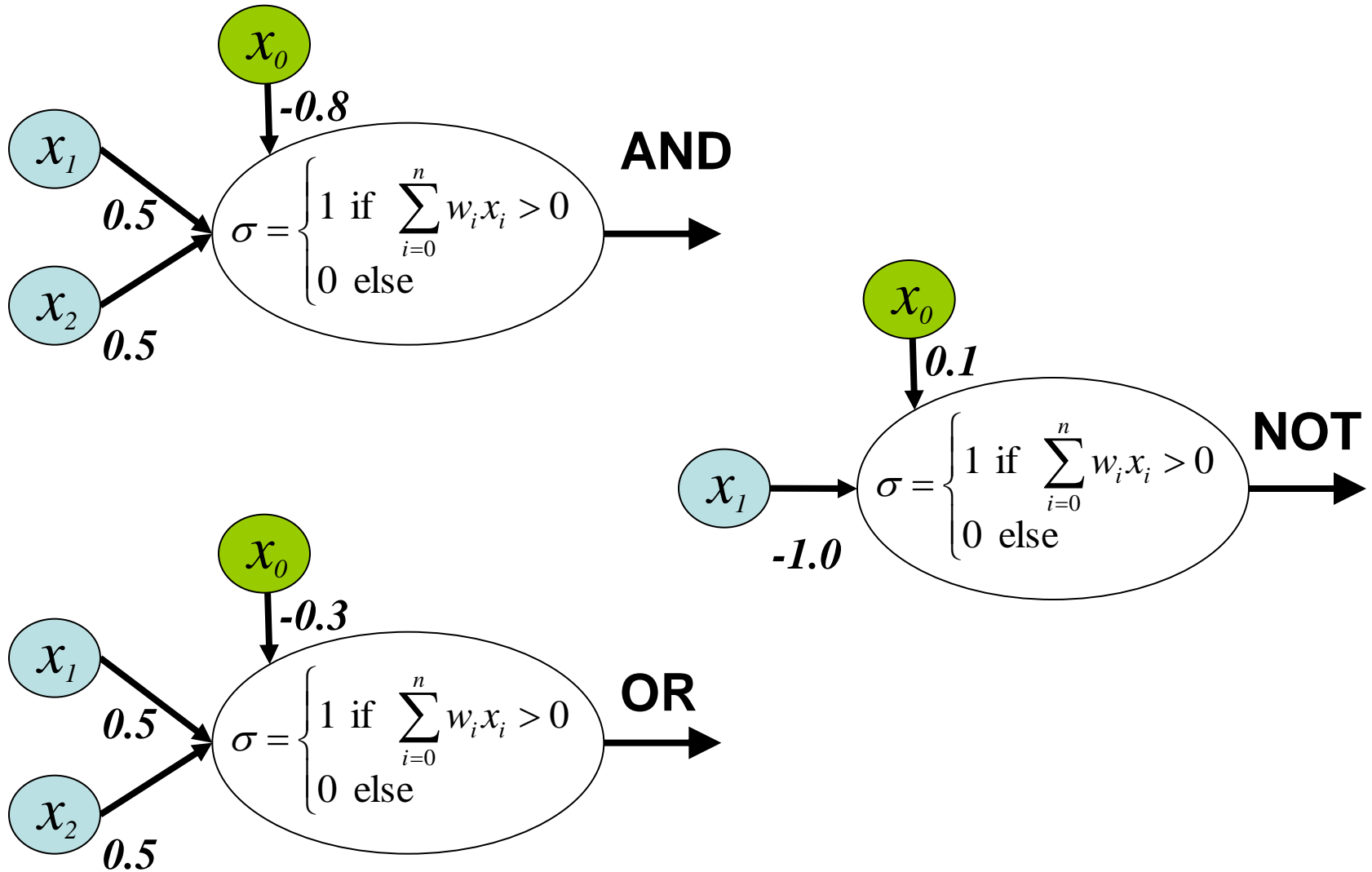

# Learning Weights

---

- Perceptron Training Rule
- Gradient Descent
- (other approaches: Genetic Algorithms)

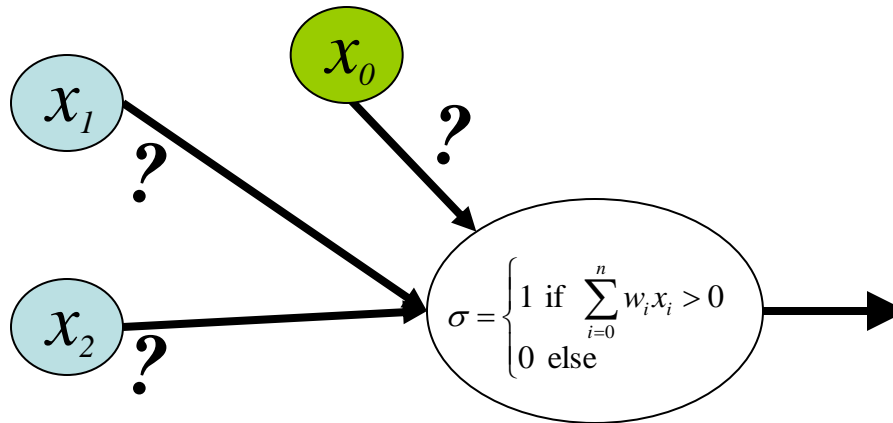

# Perceptron Training Rule

---

- Weights modified for each training example
- Update Rule:

$$w_i \leftarrow w_i + \Delta w_i$$

where

$$\Delta w_i = \eta(t - o)x_i$$

learning rate    target value    perceptron output    input value

The diagram consists of four labels at the bottom: 'learning rate', 'target value', 'perceptron output', and 'input value'. Four arrows point upwards from these labels to the corresponding terms in the equation above: an arrow from 'learning rate' to  $\eta$ , an arrow from 'target value' to  $t$ , an arrow from 'perceptron output' to  $o$ , and an arrow from 'input value' to  $x_i$ .

# What weights make XOR?

---

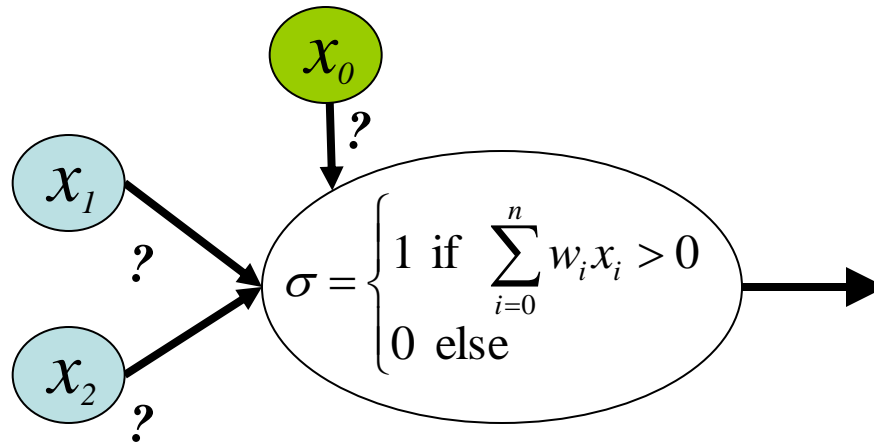

- No combination of weights works
- Perceptrons can only represent linearly separable functions

# Linear Separability

---

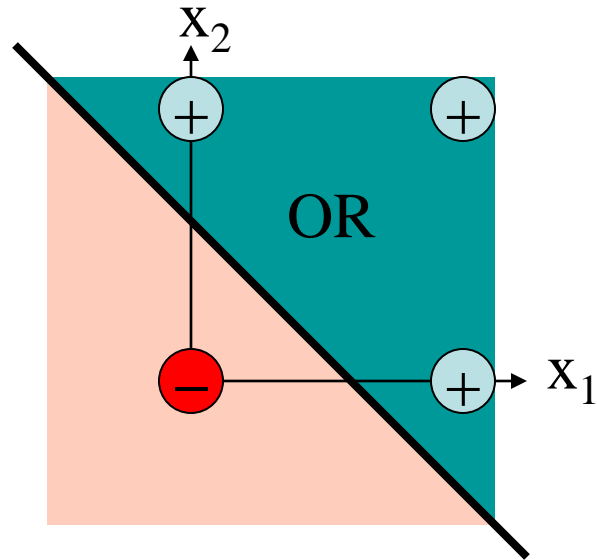

# Linear Separability

---

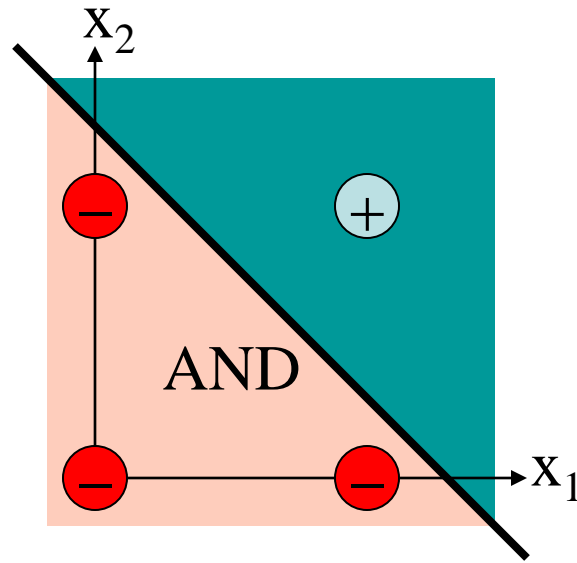

# Linear Separability

---

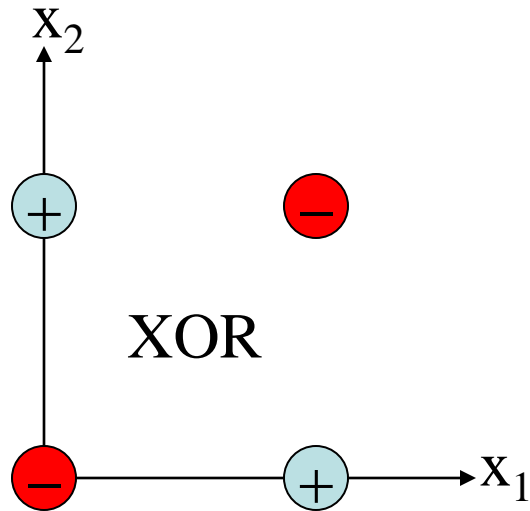

# Perceptron Training Rule

---

- Converges to the correct classification IF
  - Cases are linearly separable
  - Learning rate is slow enough
  - Proved by Minsky and Papert in 1969

**Killed widespread interest in perceptrons till the 80's**

# XOR

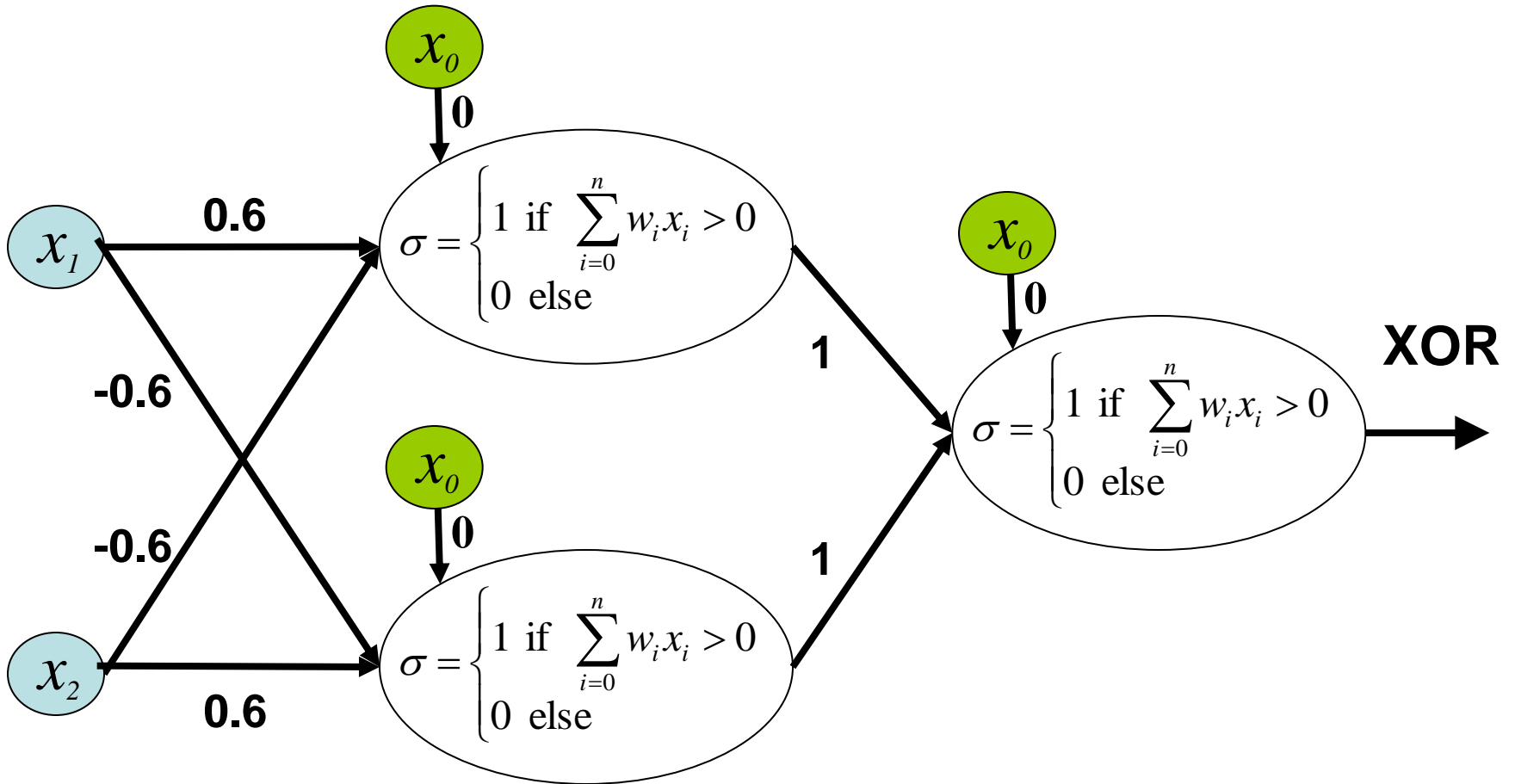

# What's wrong with perceptrons?

---

- You can always plug multiple perceptrons together to calculate any function.
- BUT...who decides what the weights are?
  - Assignment of error to parental inputs becomes a problem....
  - This is because of the threshold....
    - Who contributed the error?

# Perceptrons use a step function

---

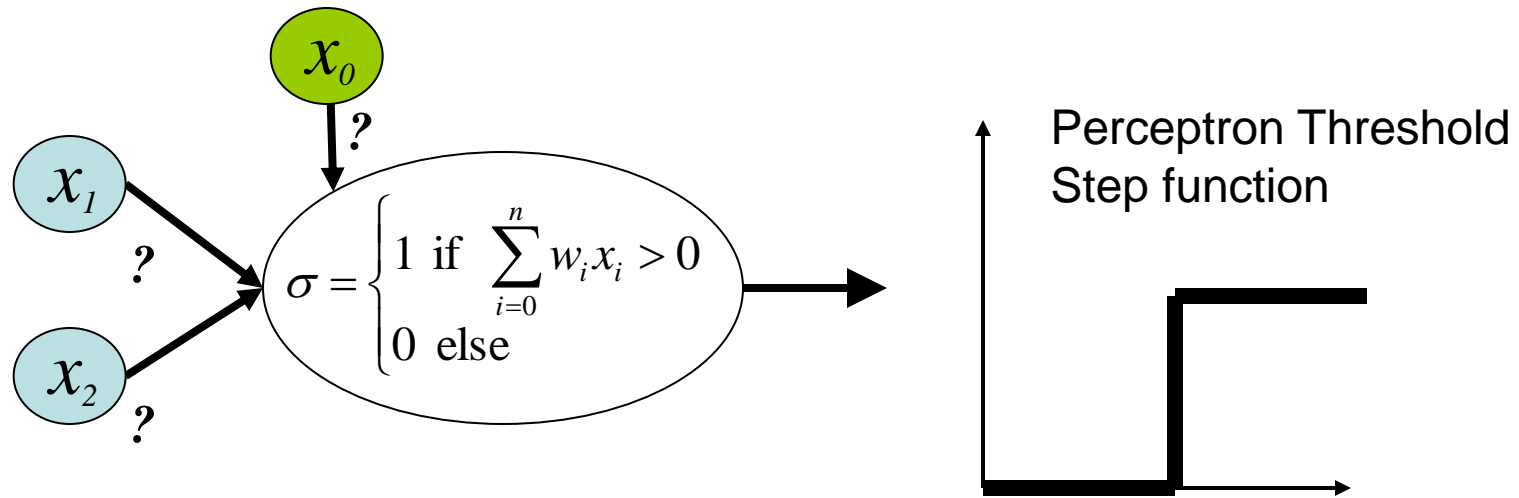

- Small changes in inputs -> either no change or large change in output.

# Solution: Differentiable Function

---

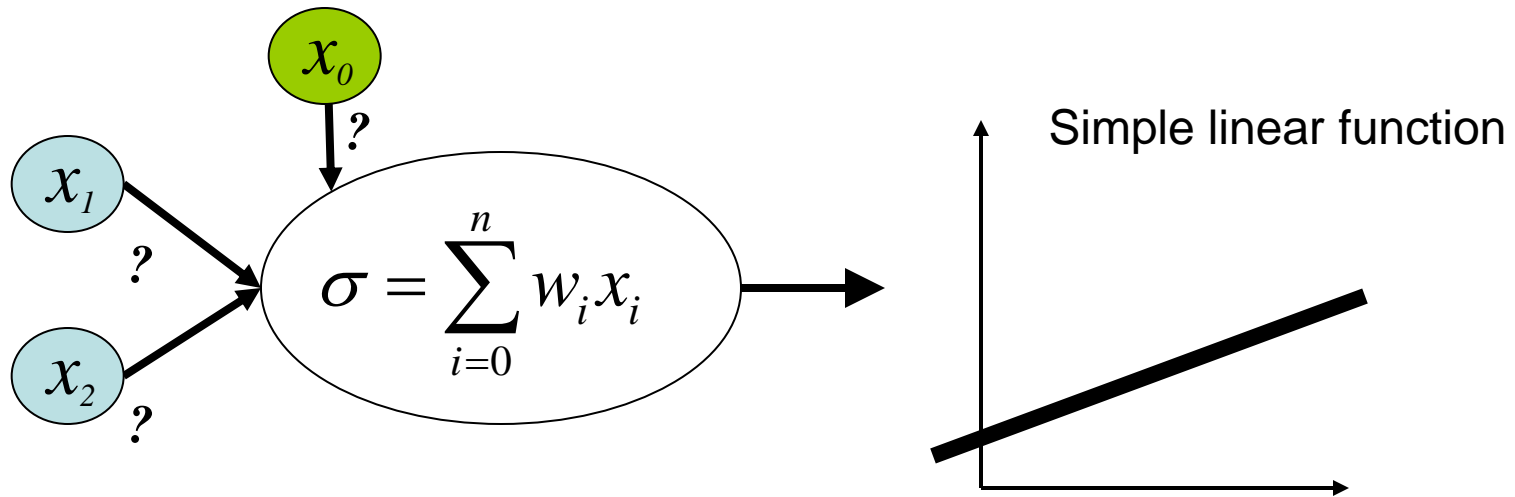

- Varying any input a little creates a perceptible change in the output
- We can now characterize how *error* changes  $w_i$  even in multi-layer case

# Measuring error for linear units

---

- Output Function

$$\sigma(\vec{x}) = \vec{w} \cdot \vec{x}$$

- Error Measure:

$$E(\vec{w}) \equiv \frac{1}{2} \sum_{d \in D} (t_d - o_d)^2$$

data

target  
value

linear unit  
output

# Gradient Descent

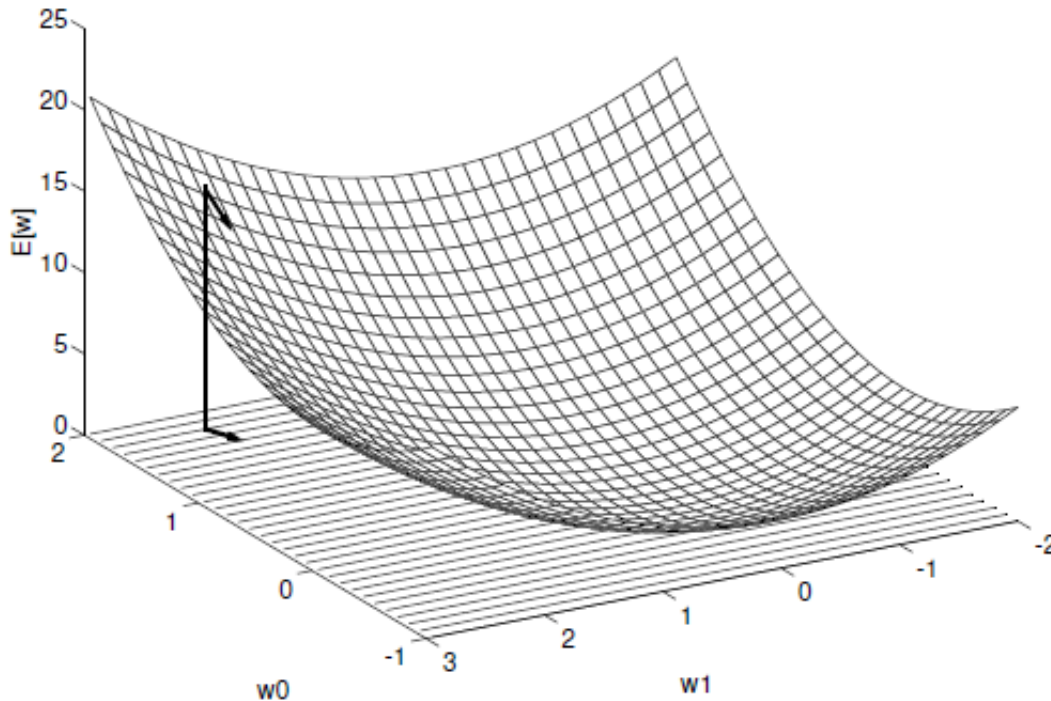

**Gradient:**

$$\nabla E[\vec{w}] \equiv \left[ \frac{\partial E}{\partial w_0}, \frac{\partial E}{\partial w_1}, \dots, \frac{\partial E}{\partial w_n} \right]$$

**Training rule:**

$$\Delta \vec{w} = -\eta \nabla E[\vec{w}]$$

$$\Delta w_i = -\eta \frac{\partial E}{\partial w_i}$$

# Gradient Descent Rule

---

$$\begin{aligned}\frac{\partial E}{\partial w_i} &\equiv \frac{\partial}{\partial w_i} \frac{1}{2} \sum_{d \in D} (t_d - o_d)^2 \\ &= \sum_{d \in D} (t_d - o_d) (-x_{i,d})\end{aligned}$$

**Update Rule:**

$$w_i \leftarrow w_i + \eta \sum_{d \in D} (t_d - o_d) x_{i,d}$$

# Gradient Descent for Multiple Layers

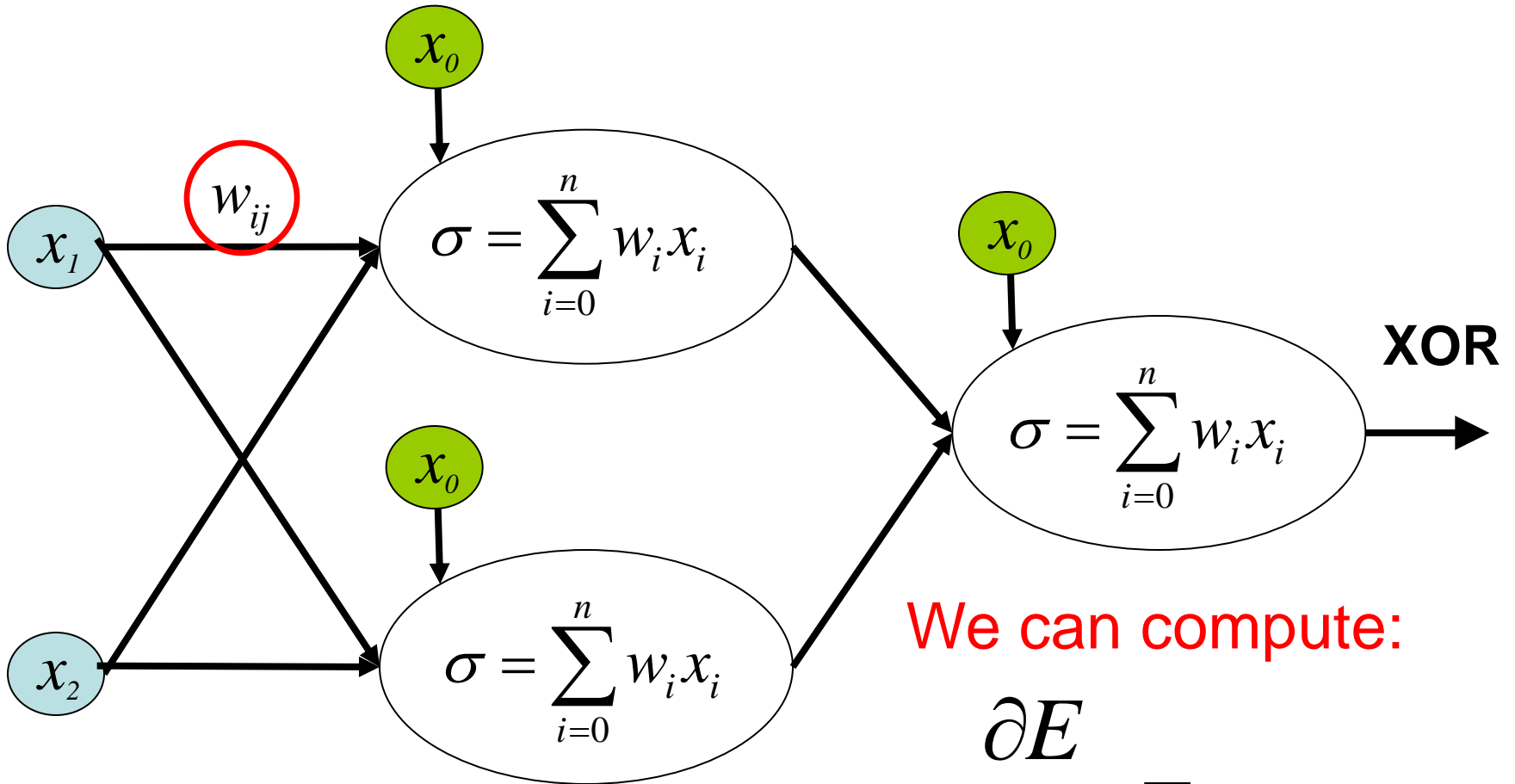

We can compute:

$$\frac{\partial E}{\partial w_{ij}} = \dots$$

# Gradient Descent vs. Perceptrons

---

- Perceptron Rule & Threshold Units
  - Learner converges on an answer ONLY IF data is linearly separable
  - Can't assign proper error to parent nodes
- Gradient Descent
  - (locally) Minimizes error even if examples are not linearly separable
  - Works for multi-layer networks
    - But...**linear units** only make linear decision surfaces (can't learn XOR even with many layers)
  - And the step function isn't differentiable...

# A compromise function

- Perceptron

$$output = \begin{cases} 1 & \text{if } \sum_{i=0}^n w_i x_i > 0 \\ 0 & \text{else} \end{cases}$$

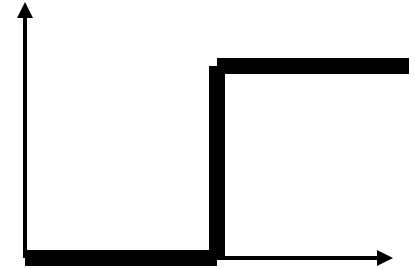

- Linear

$$output = net = \sum_{i=0}^n w_i x_i$$

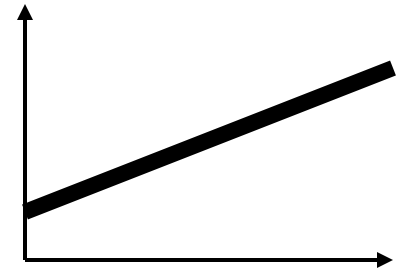

- Sigmoid (Logistic)

$$output = \sigma(net) = \frac{1}{1 + e^{-net}}$$

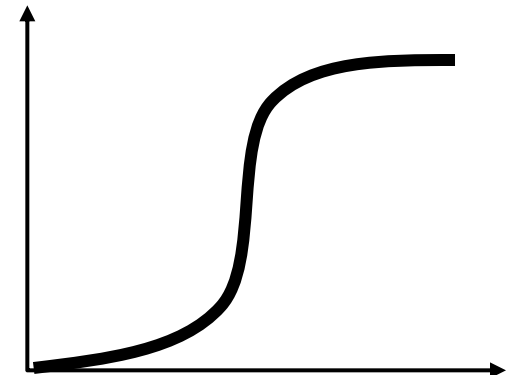

# The sigmoid (logistic) unit

---

- Has differentiable function
  - Allows gradient descent
- Can be used to learn non-linear functions

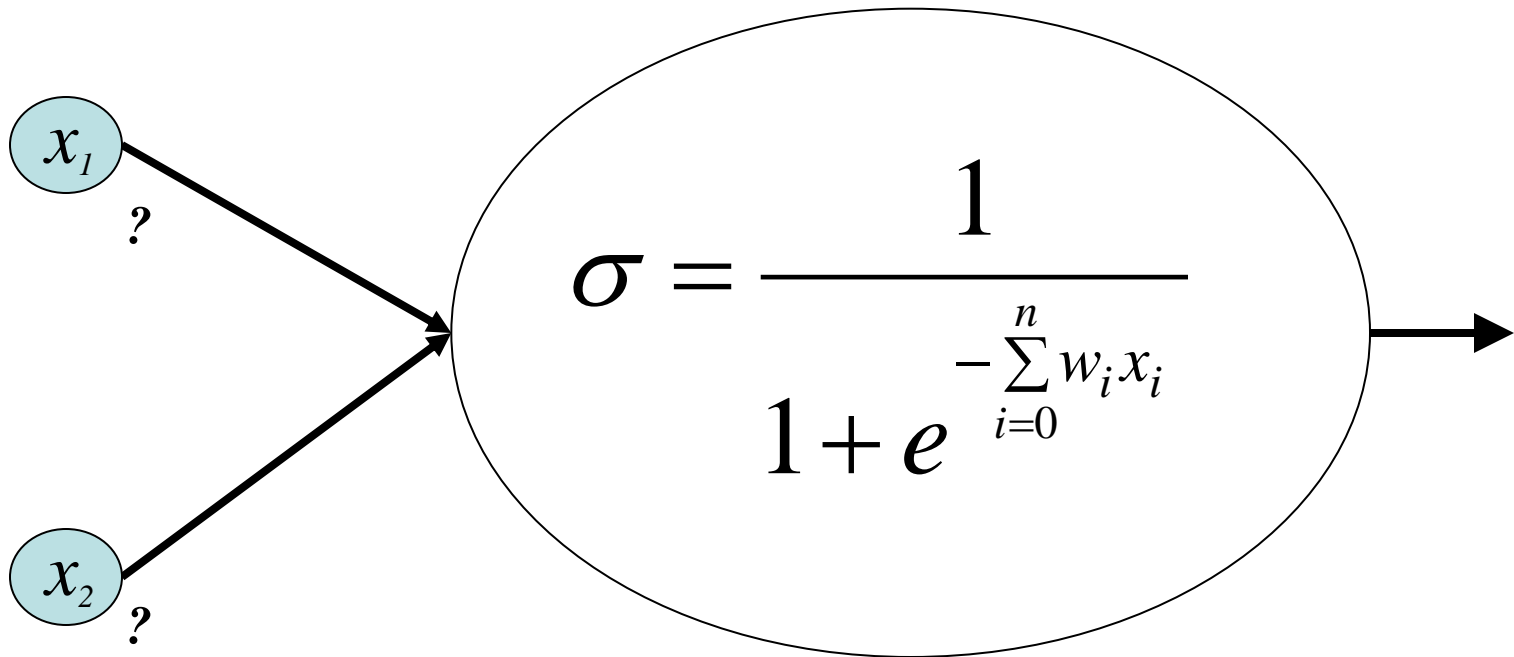

# Logistic function

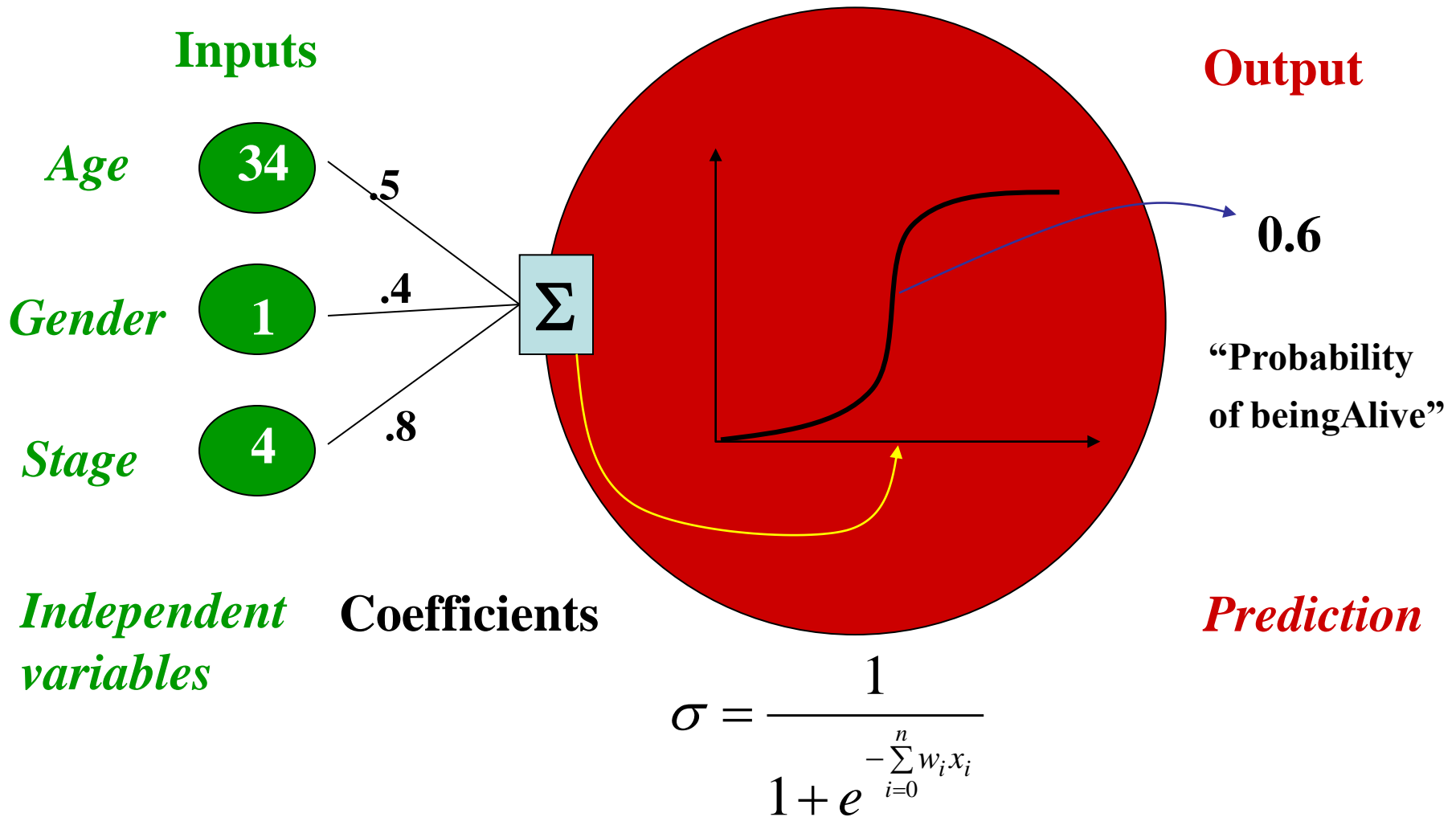

# Neural Network Model

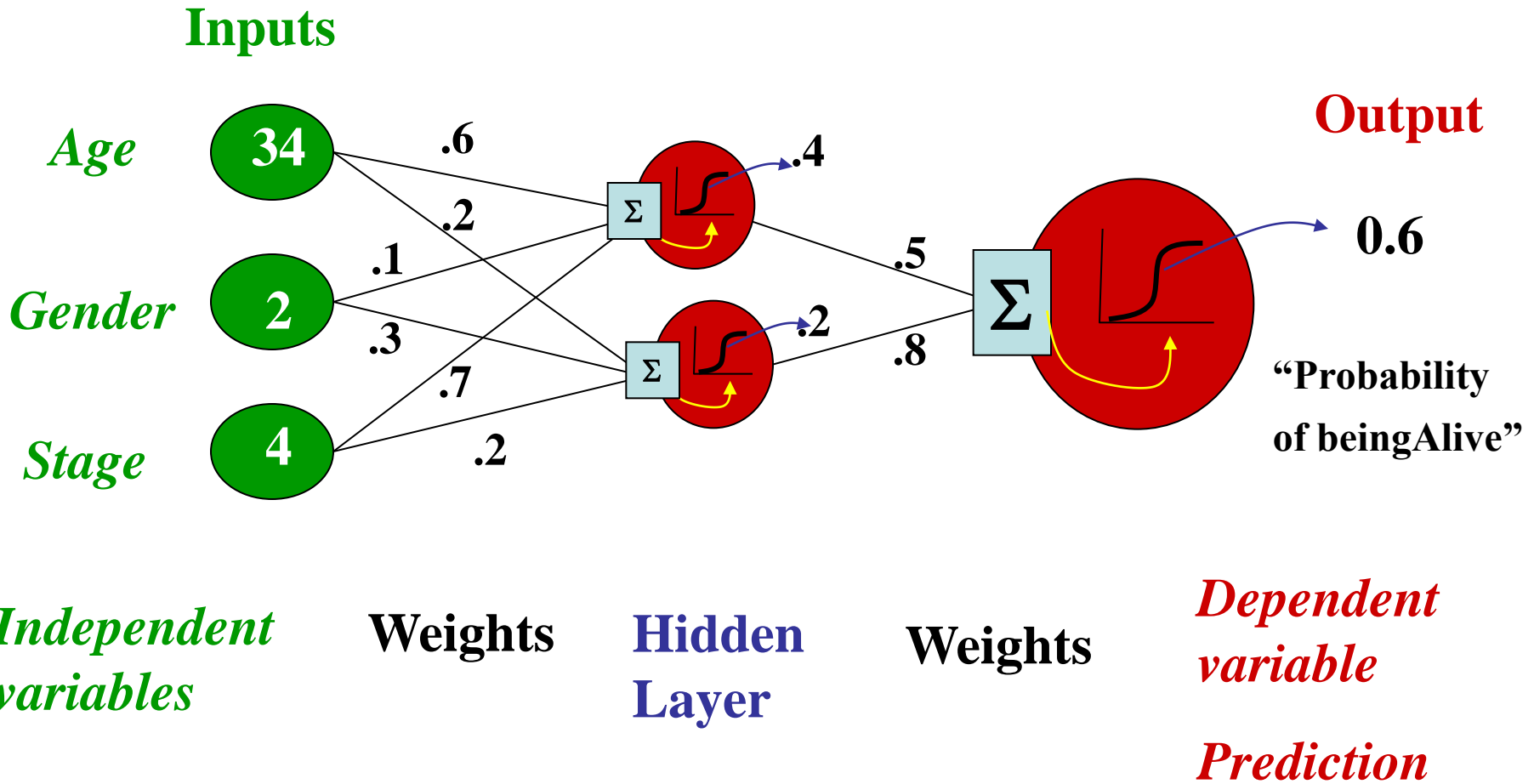

# Getting an answer from a NN

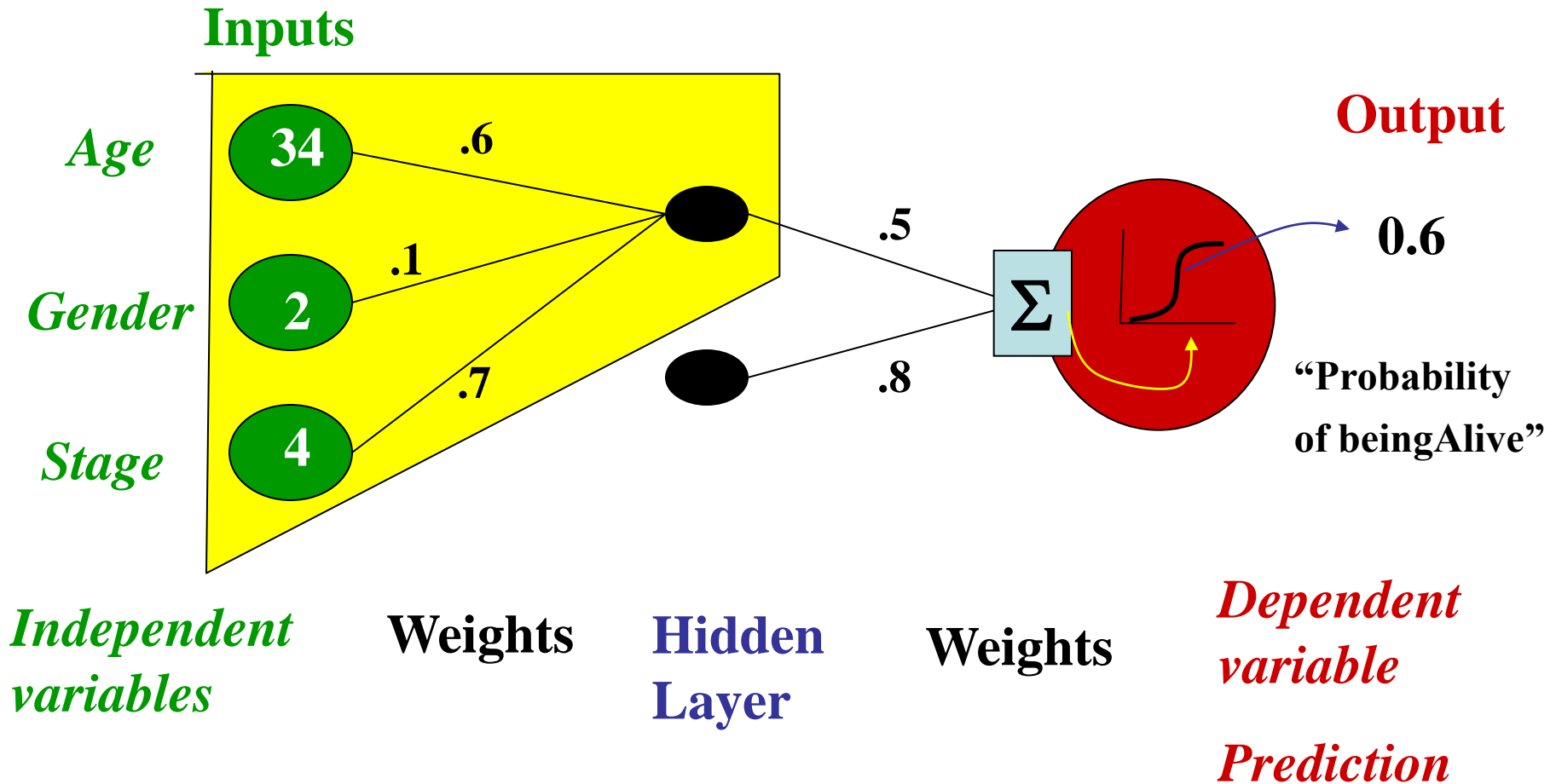

# Getting an answer from a NN

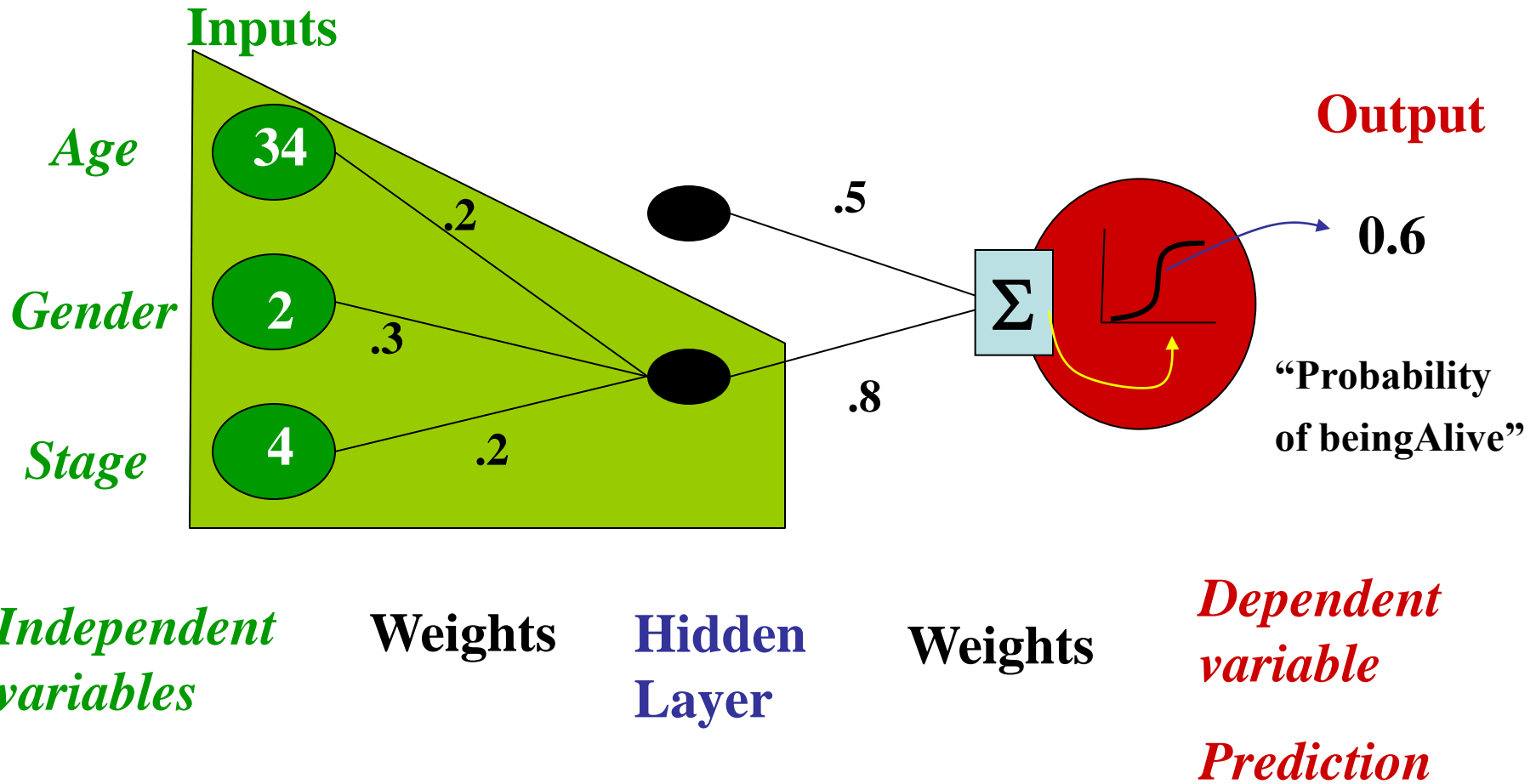

# Getting an answer from a NN

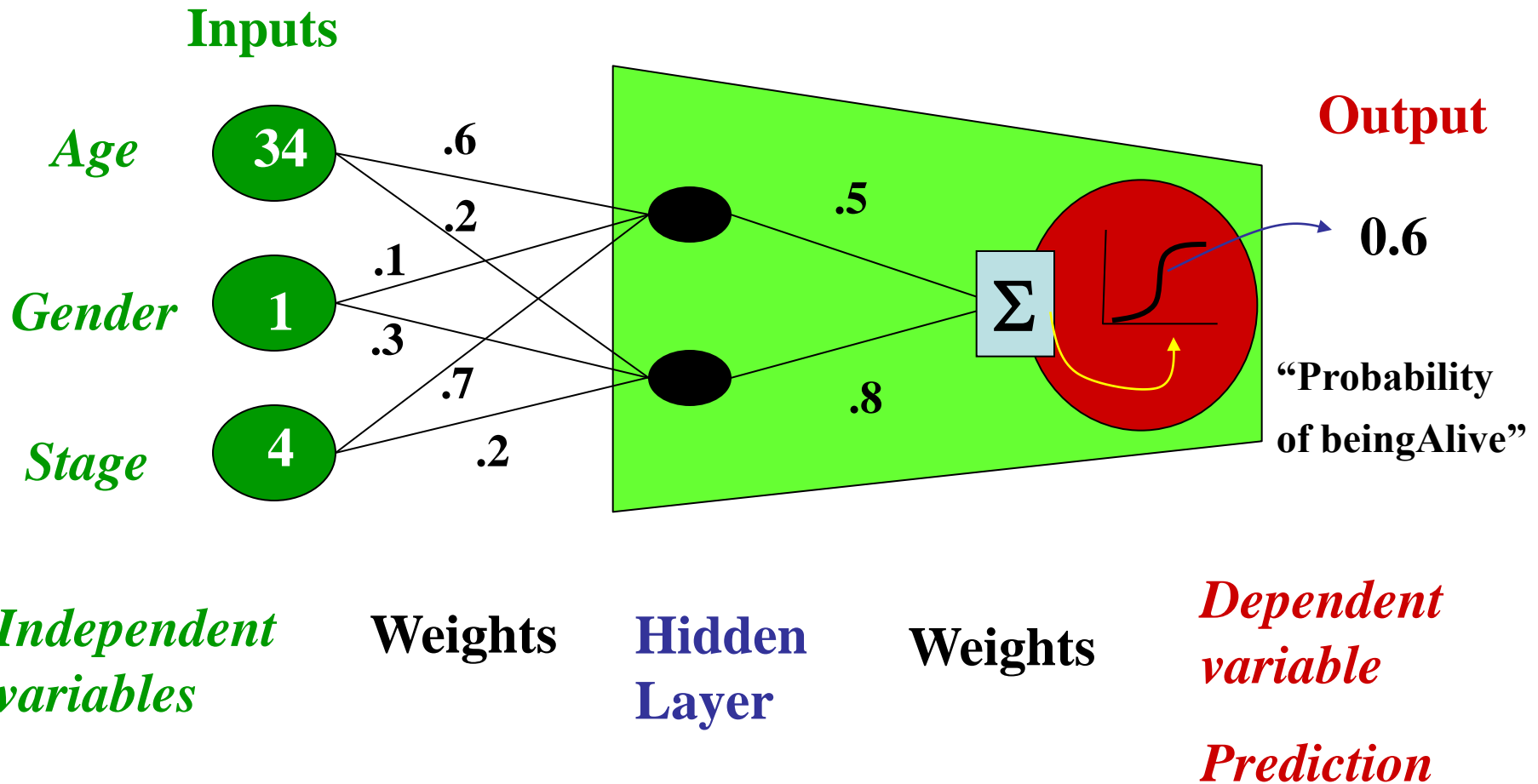

# Minimizing the Error

---

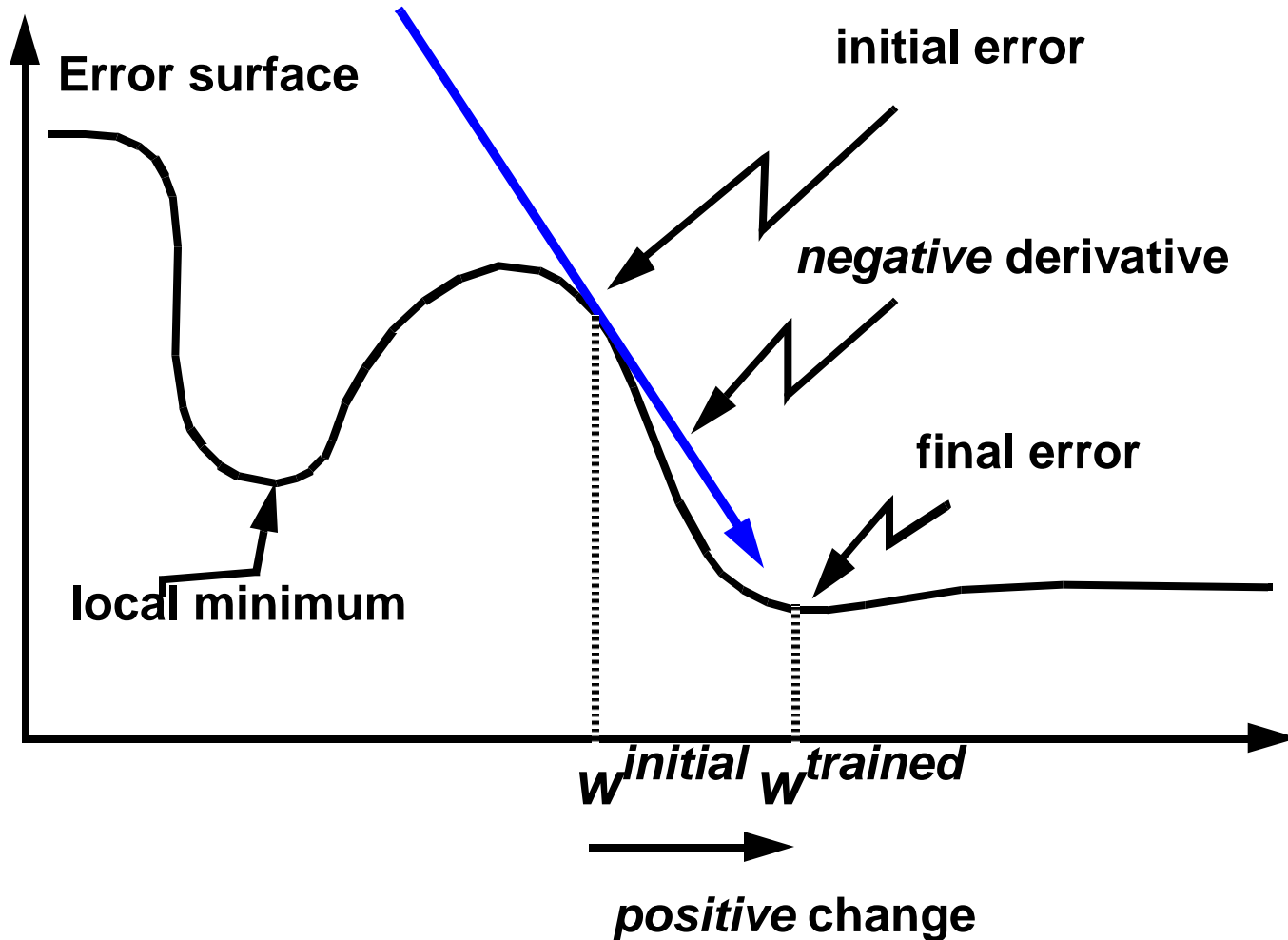

# Differentiability is key!

---

- Sigmoid is easy to differentiate

$$\frac{\partial \sigma(y)}{\partial y} = \sigma(y) \cdot (1 - \sigma(y))$$

- For gradient descent on multiple layers, a little dynamic programming can help:
  - Compute errors at each output node
  - Use these to compute errors at each hidden node
  - Use these to compute errors at each input node

# The Backpropagation Algorithm

---

For each input training example,  $\langle \vec{x}, \vec{t} \rangle$

1. Input instance  $\vec{x}$  to the network and compute the output  $o_u$  for every unit  $u$  in the network

2. For each output unit  $k$ , calculate its error term  $\delta_k$

$$\delta_k \leftarrow o_k (1 - o_k) (t_k - o_k)$$

3. For each hidden unit  $h$ , calculate its error term  $\delta_h$

$$\delta_h \leftarrow o_h (1 - o_h) \sum_{k \in \text{outputs}} w_{hk} \delta_k$$

4. Update each network weight  $w_{ji}$

$$w_{ji} \leftarrow w_{ji} + \eta \delta_j x_{ji}$$

# Learning Weights

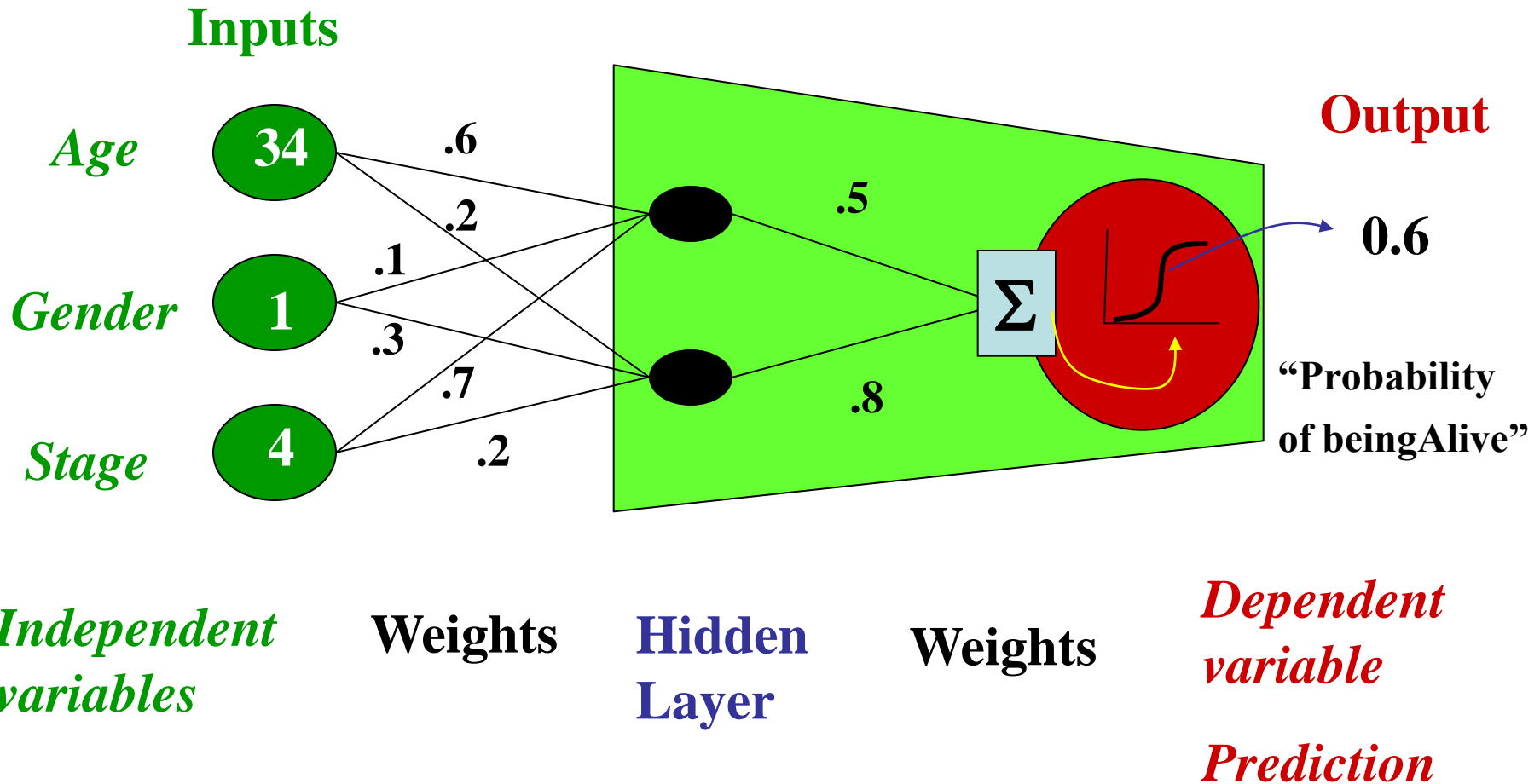

# The fine print

---

- Don't implement back-propagation
  - Use a package
  - Better second-order or variable step-size optimization techniques exist
- Feature normalization
  - Typical to normalize inputs to lie in  $[0,1]$ 
    - (and outputs must be normalized)
- Problems with NN training:
  - Slow training times
  - Local minima

# Minimizing the Error

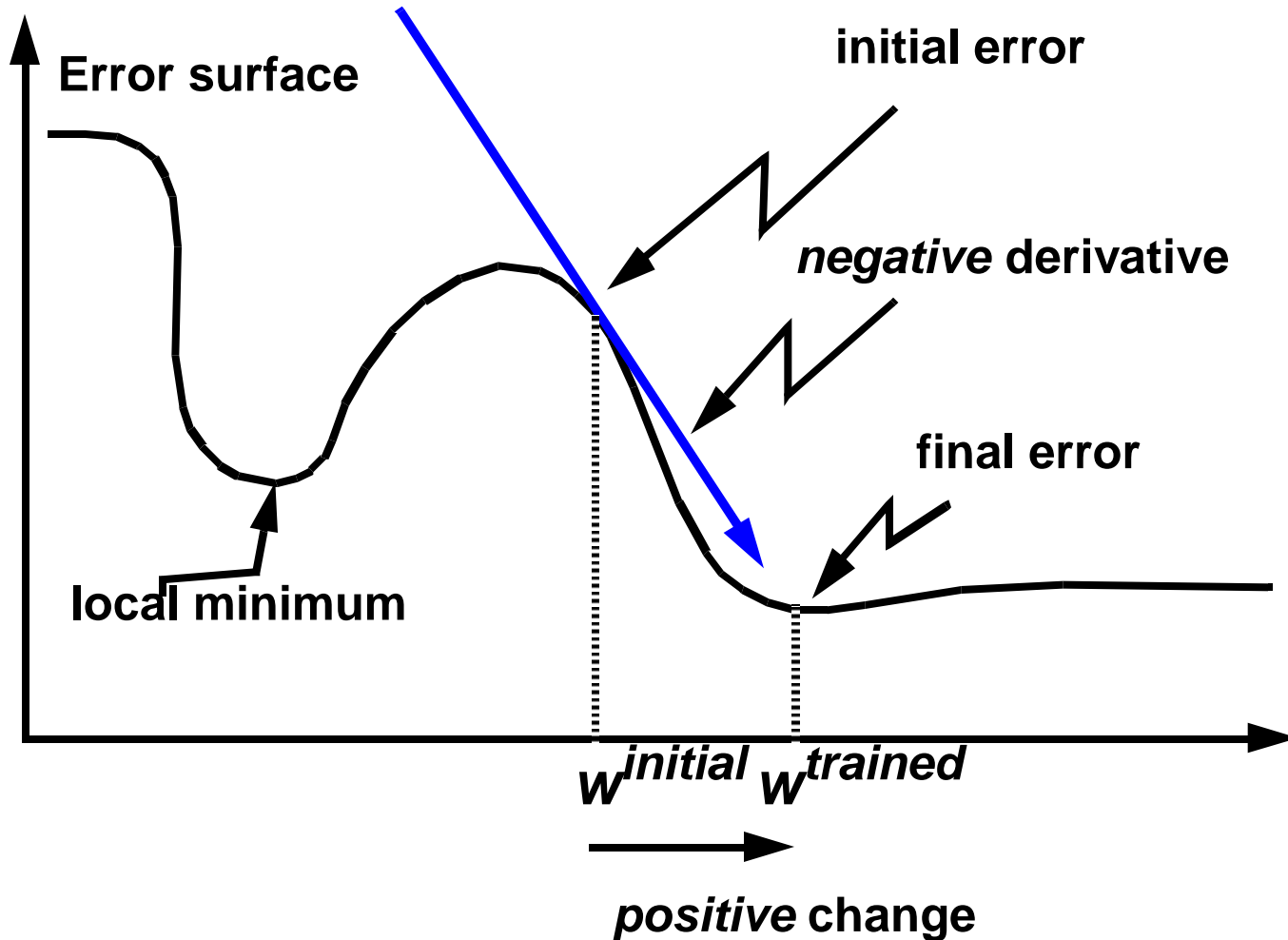

# Expressive Power of ANNs

---

- Universal Function Approximator:
  - Given enough hidden units, can approximate *any* continuous function  $f$
- Need 2+ hidden units to learn XOR
- Why not use millions of hidden units?
  - Efficiency (training is slow)
  - Overfitting

# Overfitting

---

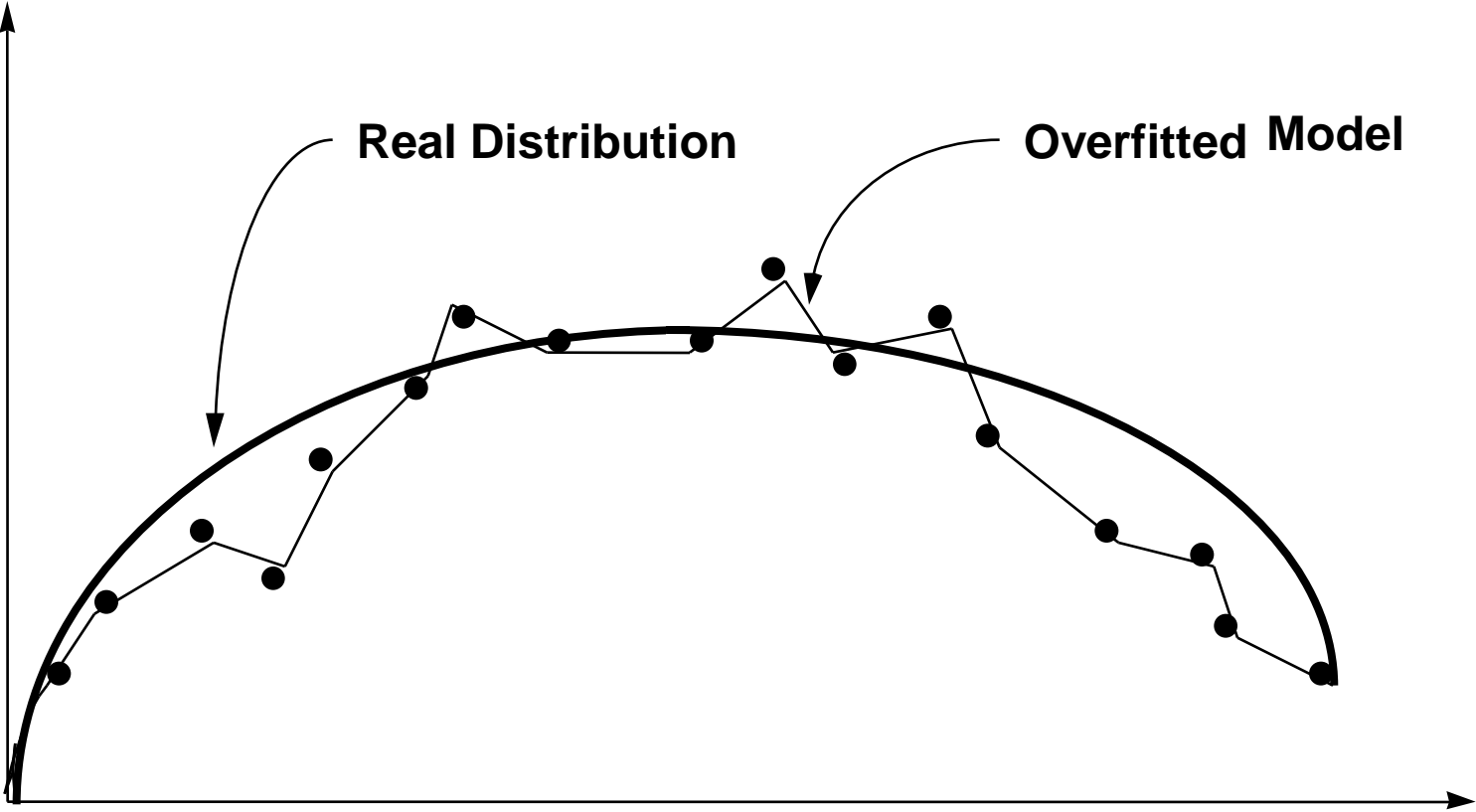

# Combating Overfitting in Neural Nets

---

- Many techniques
- Two popular ones:
  - Early Stopping
    - Use “a lot” of hidden units
    - Just don’t over-train
  - Cross-validation
    - Test different architectures to choose “right” number of hidden units

# Early Stopping

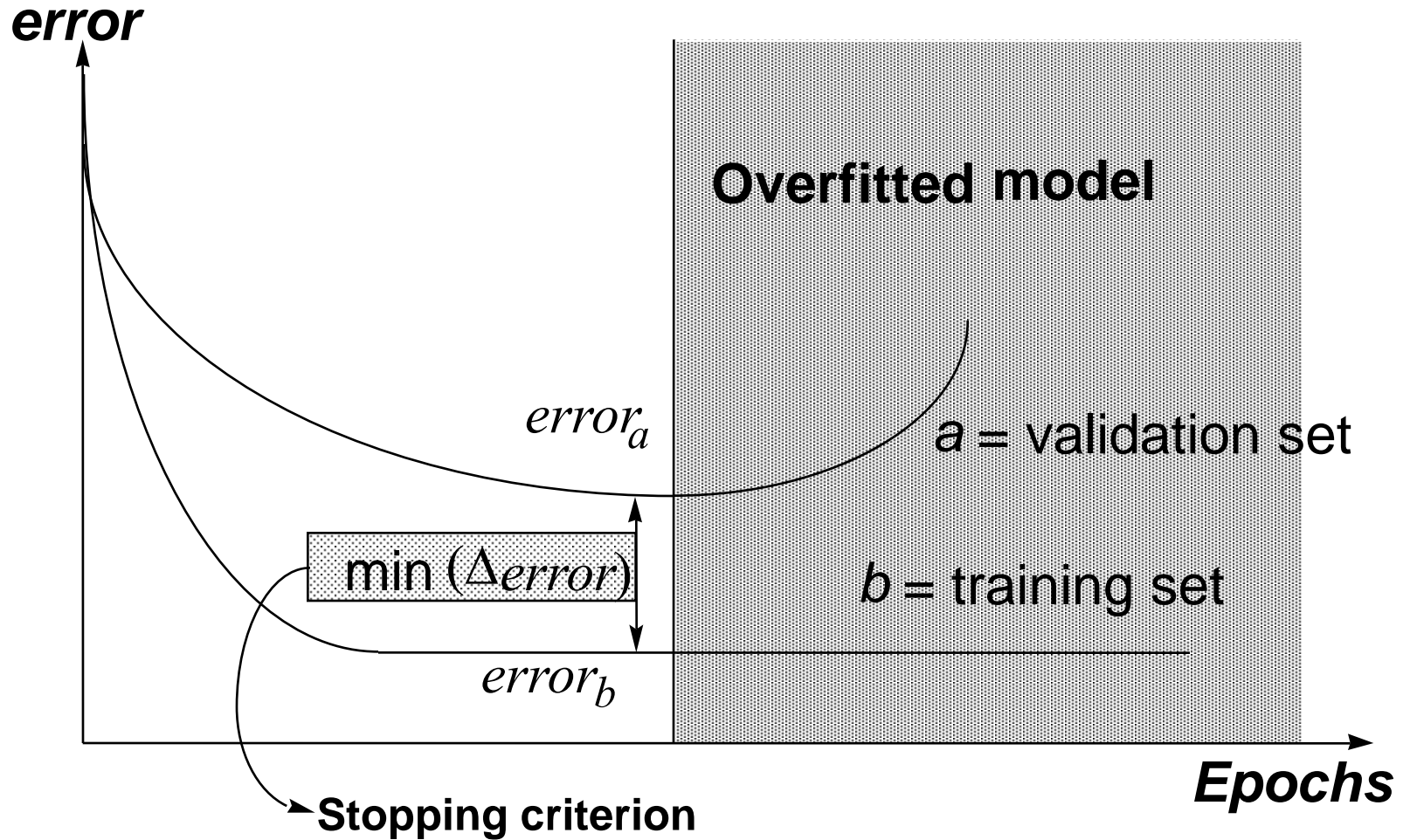

# Cross-validation

---

- Cross-validation: general-purpose technique for model selection
  - E.g., “how many hidden units should I use?”
- More extensive version of validation-set approach.

# Cross-validation

---

- Break training set into  $k$  sets
- For each model  $M$ 
  - For  $i=1\dots k$ 
    - Train  $M$  on all but set  $i$
    - Test on set  $i$
- Output  $M$  with highest average test score, trained on full training set

# Summary of Neural Networks

---

When are Neural Networks useful?

- Instances represented by attribute-value pairs
  - Particularly when attributes are **real valued**
- The target function is
  - Discrete-valued
  - **Real-valued**
  - **Vector-valued**
- Training examples may contain errors
- Fast evaluation times are necessary

When not?

- **Fast training times** are necessary
- **Understandability** of the function is required

# Summary of Neural Networks

---

Non-linear regression technique that is trained with gradient descent.

Question: How important is the biological metaphor?

# Advanced Topics in Neural Nets

---

- Batch Move vs. incremental
- Hidden Layer Representations
- Hopfield Nets
- Neural Networks on Silicon
- Neural Network language models

# Incremental vs. Batch Mode

---

**Incremental mode** Gradient Descent:

Do until satisfied

- For each training example  $d$  in  $D$ 
  1. Compute the gradient  $\nabla E_d[\vec{w}]$
  2.  $\vec{w} \leftarrow \vec{w} - \eta \nabla E_d[\vec{w}]$

**Batch mode** Gradient Descent:

Do until satisfied

1. Compute the gradient  $\nabla E_D[\vec{w}]$
2.  $\vec{w} \leftarrow \vec{w} - \eta \nabla E_D[\vec{w}]$

$$E_D[\vec{w}] \equiv \frac{1}{2} \sum_{d \in D} (t_d - o_d)^2$$

# Incremental vs. Batch Mode

---

- In Batch Mode we minimize:

$$E_D[\vec{w}] \equiv \frac{1}{2} \sum_{d \in D} (t_d - o_d)^2$$

- Same as computing:  $\Delta \vec{w}_D = \sum_{d \in D} \Delta \vec{w}_d$

- Then setting  $\vec{w} \leftarrow \vec{w} + \Delta \vec{w}_D$

# Advanced Topics in Neural Nets

---

- Batch Move vs. incremental
- **Hidden Layer Representations**
- Hopfield Nets
- Neural Networks on Silicon
- Neural Network language models

# Hidden Layer Representations

---

- Input->Hidden Layer mapping:
  - **representation** of input vectors tailored to the task
- Can also be exploited for *dimensionality reduction*
  - Form of **unsupervised learning** in which we output a “more compact” representation of input vectors
  - $\langle x_1, \dots, x_n \rangle \rightarrow \langle x'_1, \dots, x'_m \rangle$  where  $m < n$
  - Useful for visualization, problem simplification, data compression, etc.

# Dimensionality Reduction

---

Model:

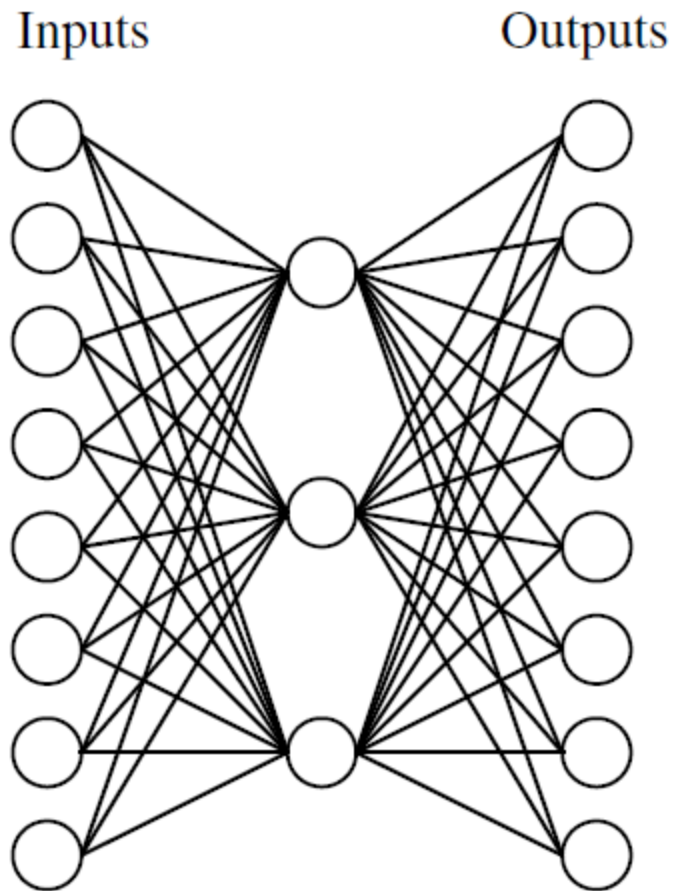

Function to learn:

Input	Output
10000000	→ 10000000
01000000	→ 01000000
00100000	→ 00100000
00010000	→ 00010000
00001000	→ 00001000
00000100	→ 00000100
00000010	→ 00000010
00000001	→ 00000001

# Dimensionality Reduction: Example

---

Input		Hidden Values		Output
10000000	→	.89 .04 .08	→	10000000
01000000	→	.01 .11 .88	→	01000000
00100000	→	.01 .97 .27	→	00100000
00010000	→	.99 .97 .71	→	00010000
00001000	→	.03 .05 .02	→	00001000
00000100	→	.22 .99 .99	→	00000100
00000010	→	.80 .01 .98	→	00000010
00000001	→	.60 .94 .01	→	00000001

# Dimensionality Reduction: Example

---

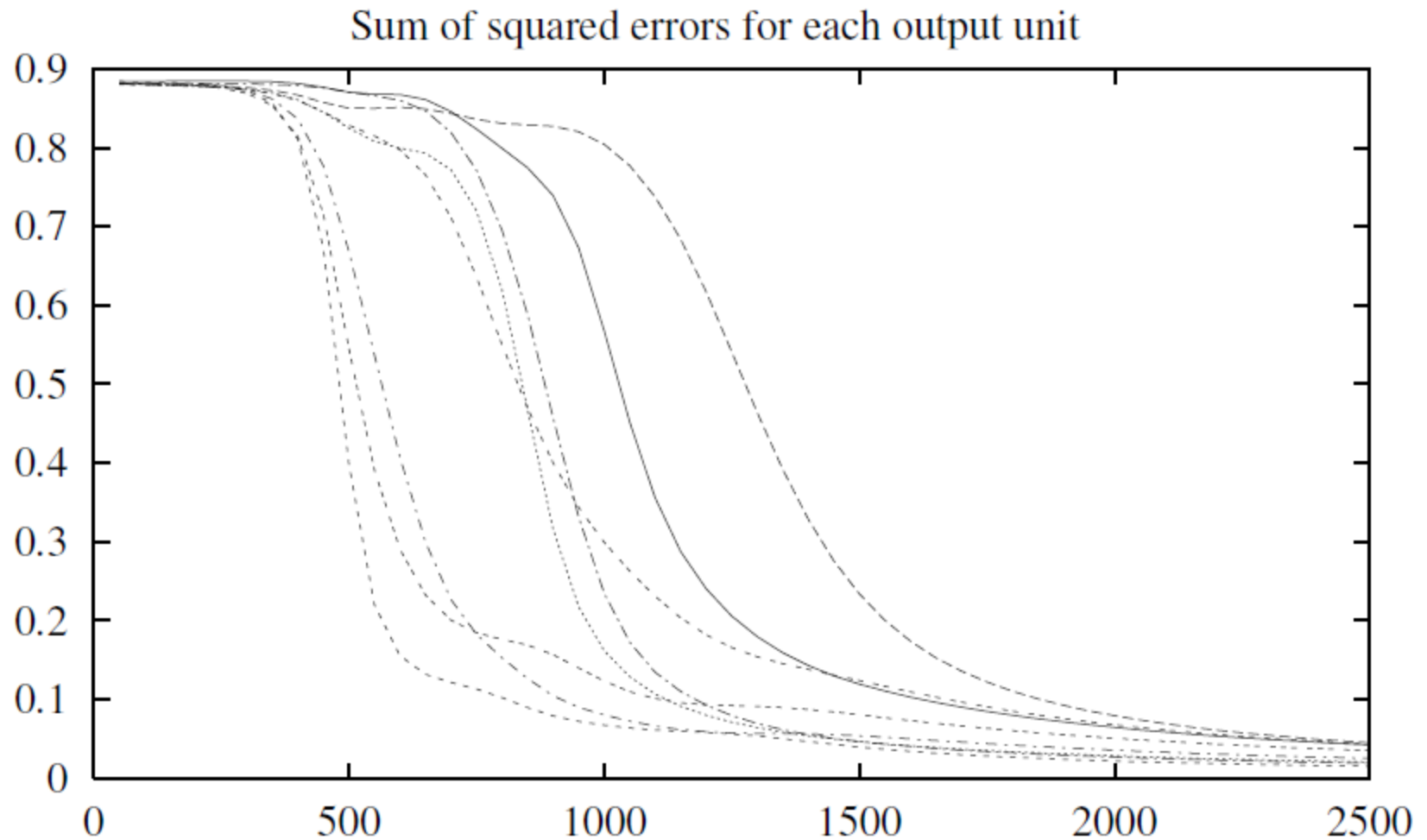

# Dimensionality Reduction: Example

---

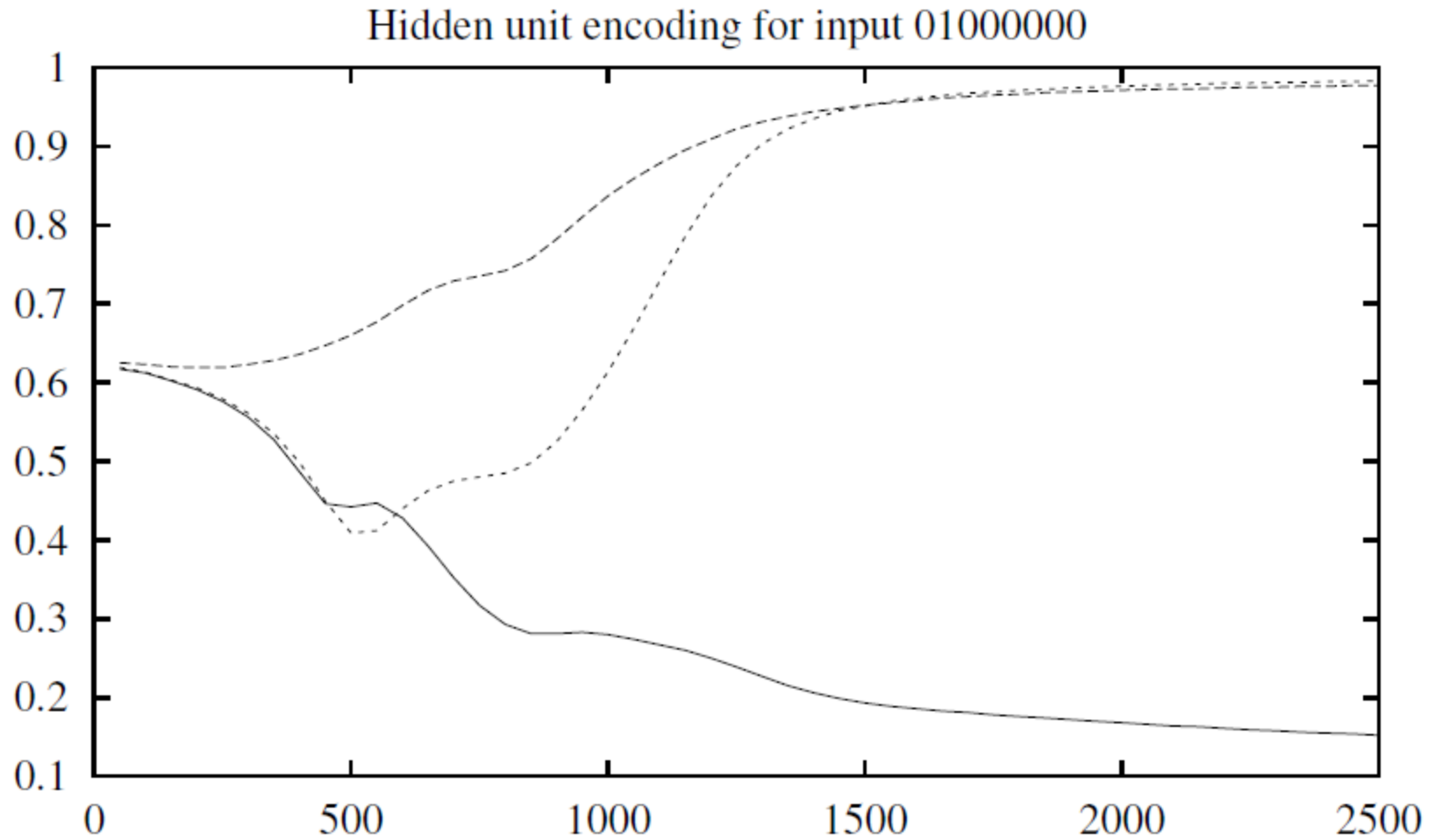

# Dimensionality Reduction: Example

---

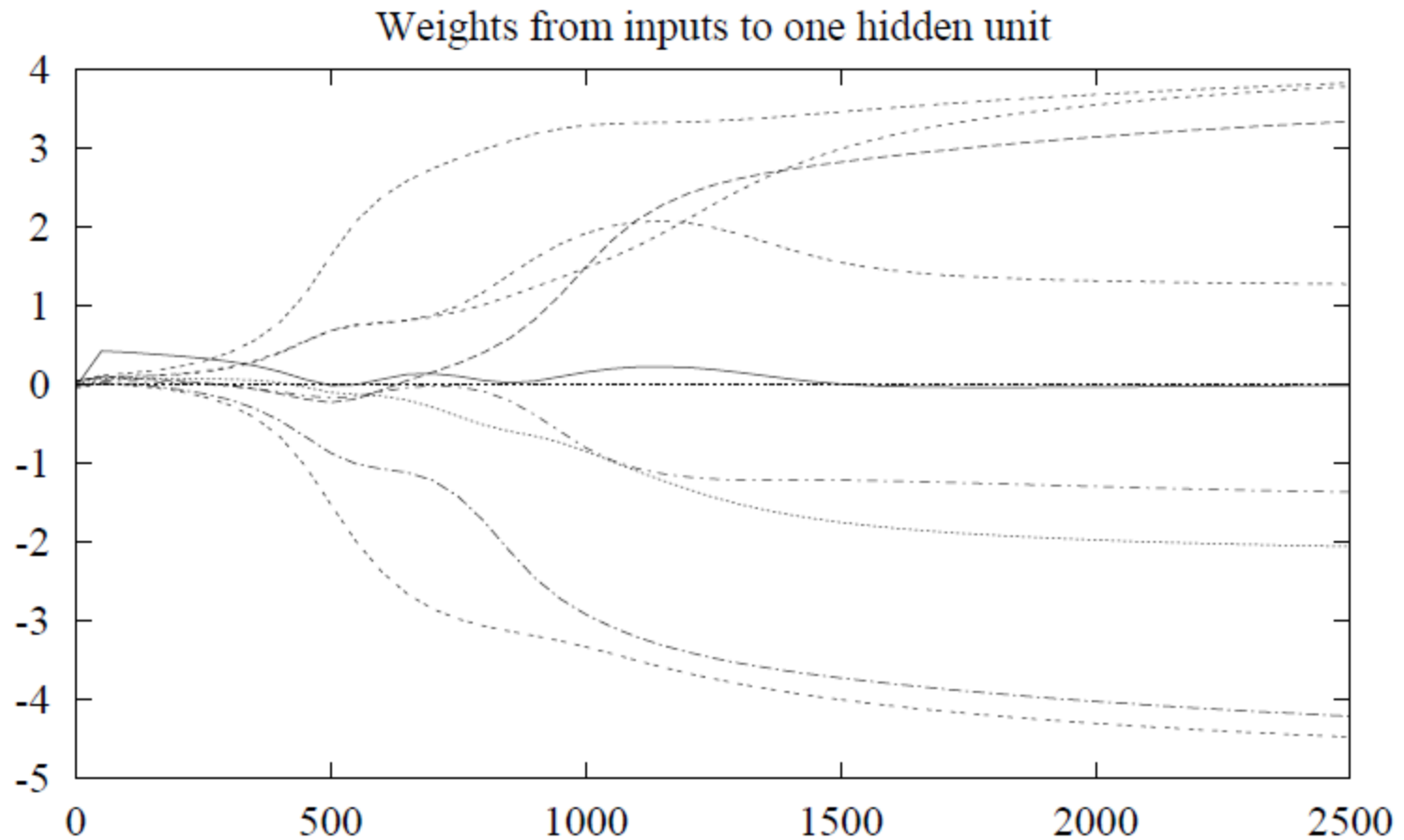

# Advanced Topics in Neural Nets

---

- Batch Move vs. incremental
- Hidden Layer Representations
- **Hopfield Nets**
- Neural Networks on Silicon
- Neural Network language models

# Advanced Topics in Neural Nets

---

- Batch Move vs. incremental
- Hidden Layer Representations
- Hopfield Nets
- **Neural Networks on Silicon**
- Neural Network language models

# Neural Networks on Silicon

---

- Currently:

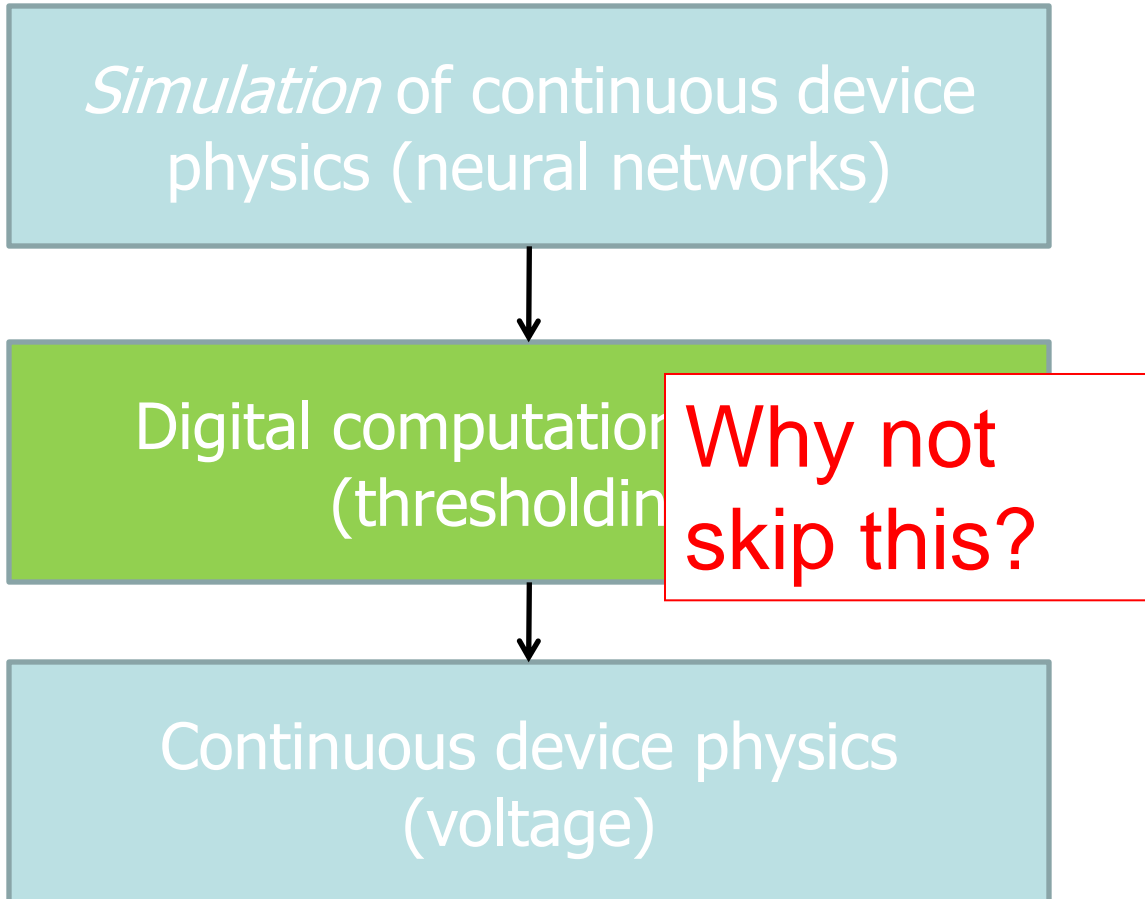

# Example: Silicon Retina

Simulates function  
of biological retina

Single-transistor  
synapses adapt to  
luminance,  
temporal contrast

Modeling retina  
directly on chip  
=> requires 100x  
less power!

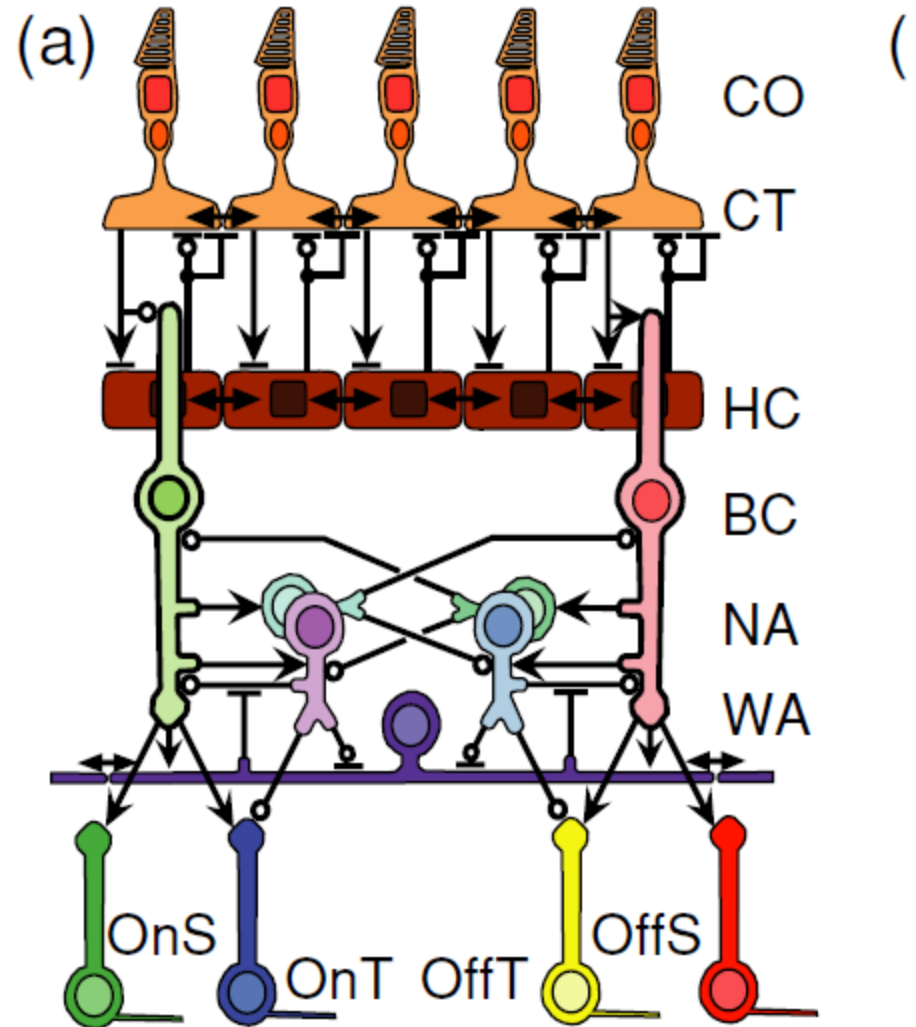

# Example: Silicon Retina

---

- Synapses modeled with single transistors

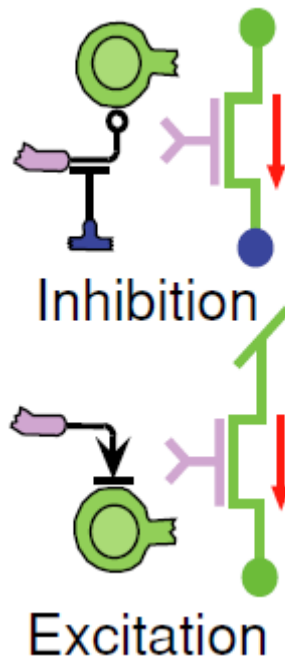

# Luminance Adaptation

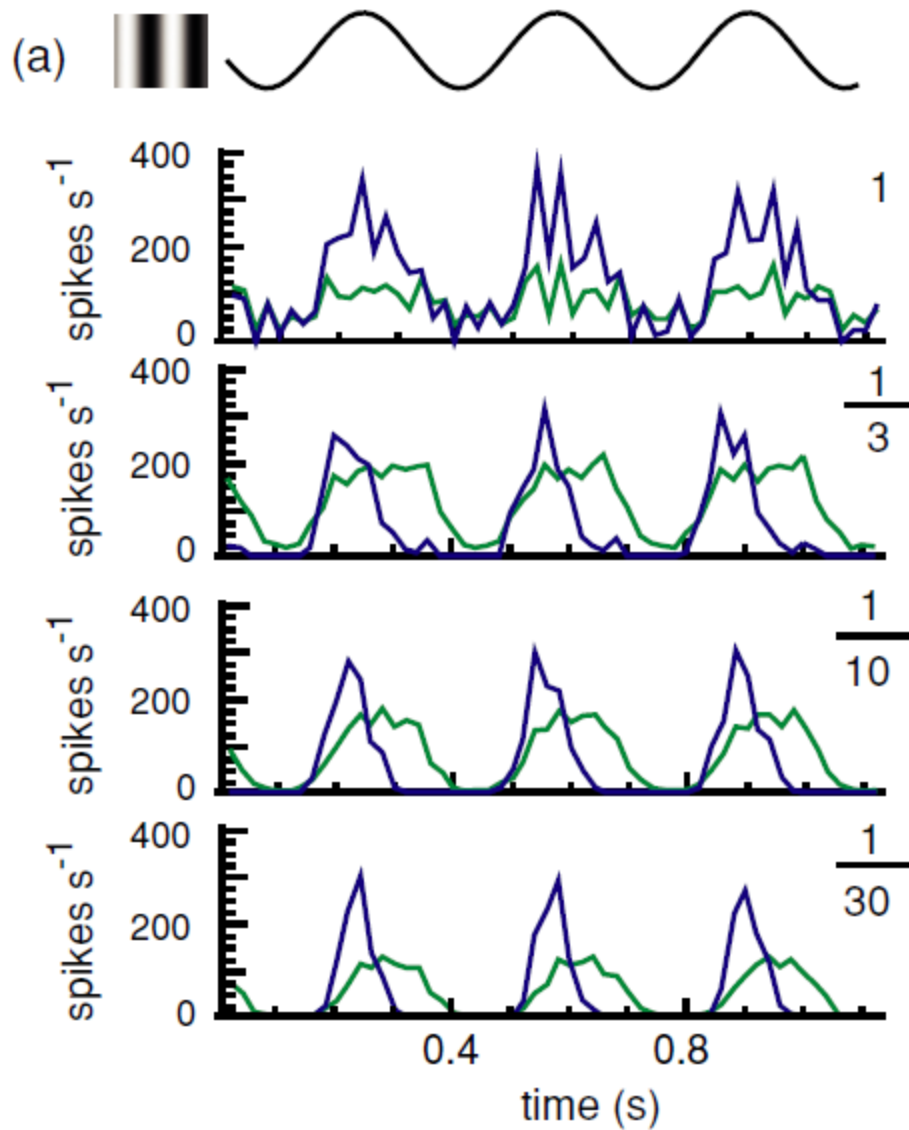

# Comparison with Mammal Data

- Real:

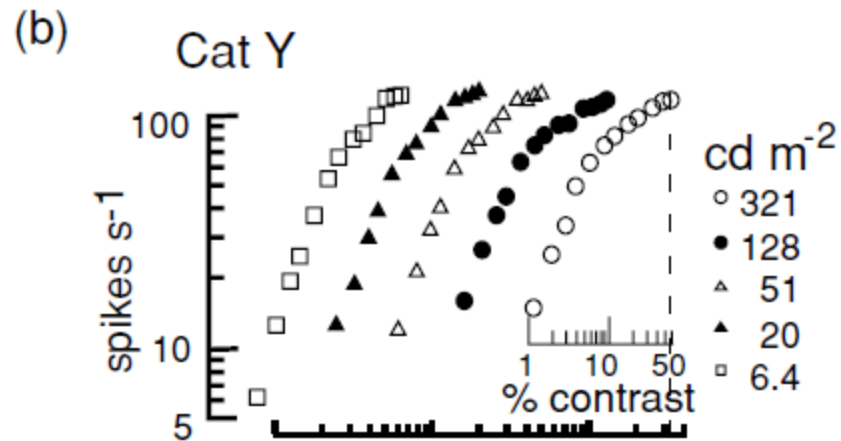

- Artificial:

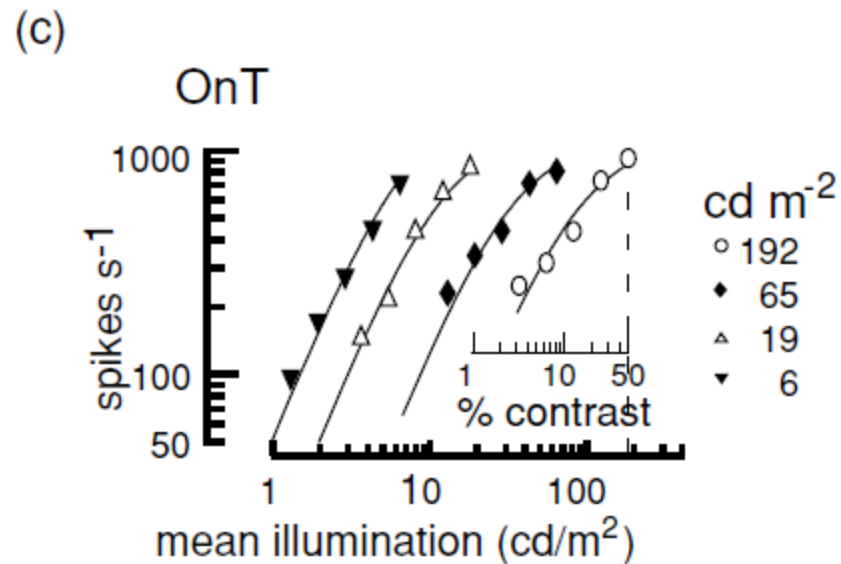

- 
- Graphics and results taken from:

INSTITUTE OF PHYSICS PUBLISHING

J. Neural Eng. 3 (2006) 257–267

JOURNAL OF NEURAL ENGINEERING

[doi:10.1088/1741-2560/3/4/002](https://doi.org/10.1088/1741-2560/3/4/002)

# **A silicon retina that reproduces signals in the optic nerve**

Kareem A Zaghoul<sup>1</sup> and Kwabena Boahen<sup>2,3</sup>

# General NN learning in silicon?

---

- *Seems* less in-vogue than in late 90s
- Interest has turned somewhat to implementing Bayesian techniques in analog silicon

# Advanced Topics in Neural Nets

---

- Batch Move vs. incremental
- Hidden Layer Representations
- Hopfield Nets
- Neural Networks on Silicon
- **Neural Network language models**

# Neural Network Language Models

---

- Statistical Language Modeling:
  - Predict probability of next word in sequence

I was headed to Madrid , \_\_\_\_\_

$P(\text{_____} = \text{"Spain"}) = 0.5,$

$P(\text{_____} = \text{"but"}) = 0.2, \text{ etc.}$

- Used in speech recognition, machine translation, (recently) information extraction

# Formally

---

- Estimate:

$$P(w_j \mid w_{j-1}, w_{j-2}, \dots, w_{j-n+1})$$
$$= P(w_j \mid h_j)$$

# Neural Network

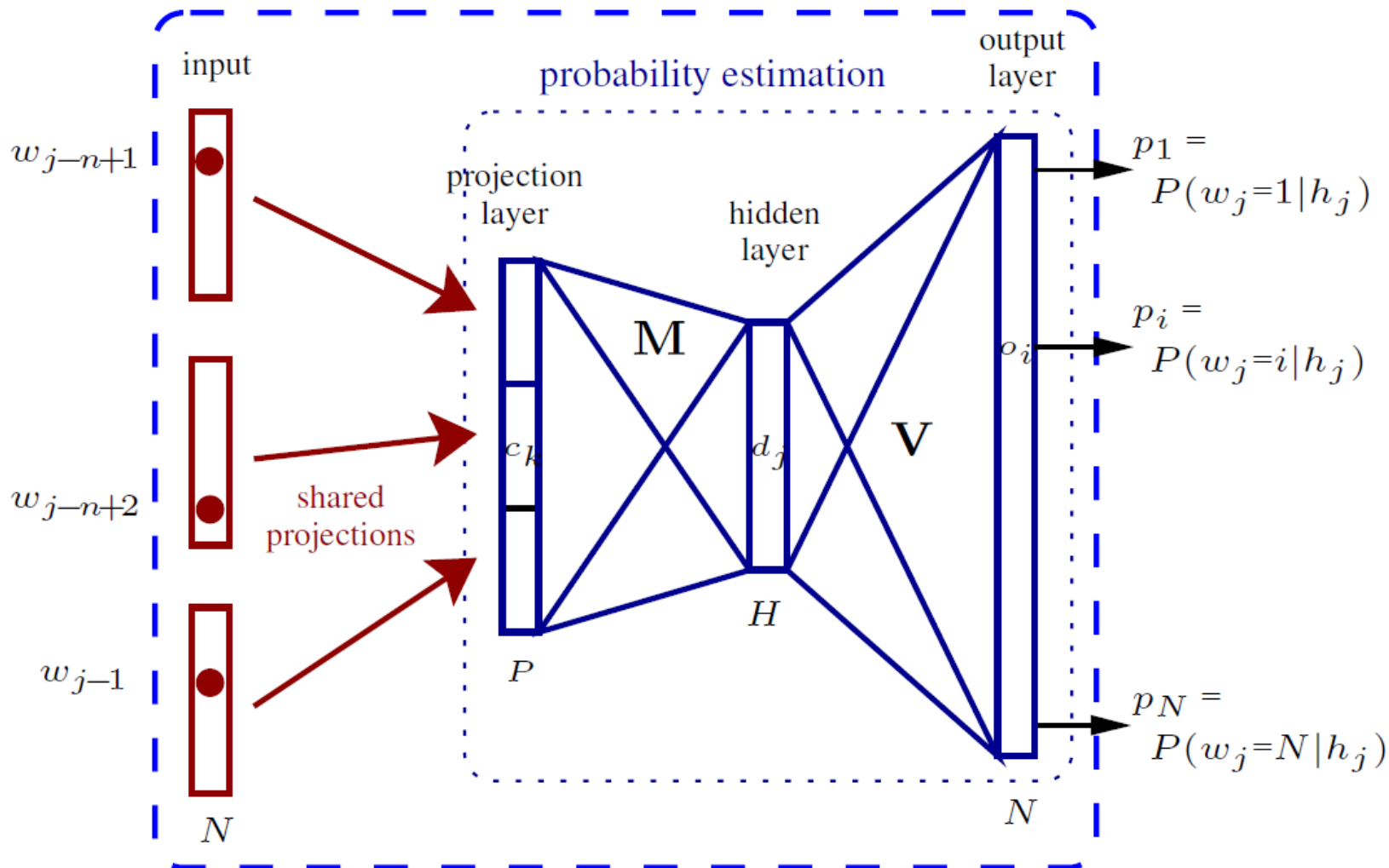

discrete representation: indices in wordlist  
 continuous representation:  $P$  dimensional vectors

LM probabilities for all words

# Optimizations

---

- Key idea – learn simultaneously:
  - vector representations of each word (120 dim)
  - predictor of next word. based on previous vectors
- Short-lists
  - Much complexity in hidden->output layer
    - Number of possible next words is large
  - Only predict a *subset* of words
    - Use a standard probabilistic model for the rest

# Design Decisions (1)

---

- Number of hidden units

size	400	500	600	1000*
Tr. time	11h20	13h50	16h15	11+16h
Px alone	100.5	100.1	99.5	94.5
interpol.	68.3	68.3	68.2	68.0
Werr	13.99%	13.97%	13.96%	13.92%

\* Interpolation of networks with 400 and 600 hidden units.

- Almost no difference...

# Design Decisions (2)

- Word representation (# of dimensions)

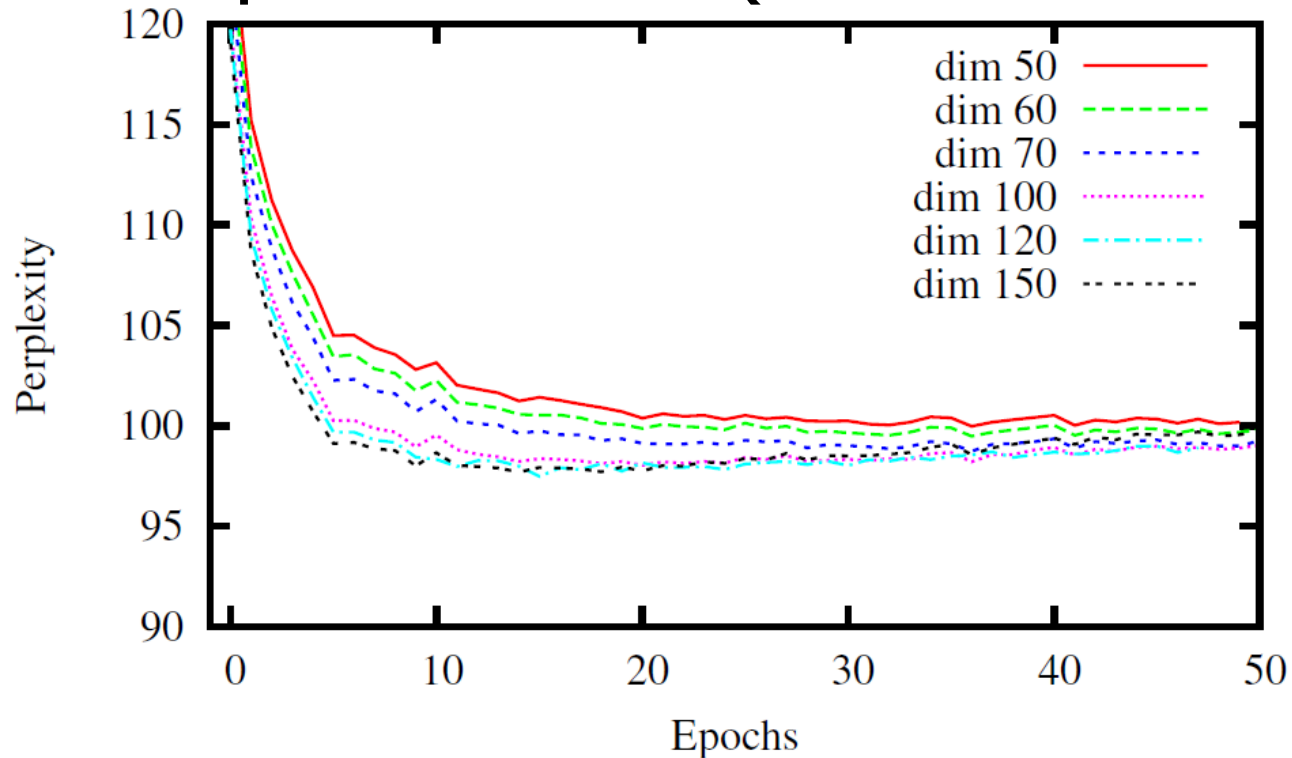

- They chose 120

# Comparison vs. state of the art

---

	Back-off LM	Neural Network LM				
Training data [#words]	600M	4M	22M	92.5M*	600M*	
Training time [h/epoch]	-	2h40	14h	9h40	12h	3 × 12h
Perplexity (NN LM alone)	-	103.0	97.5	84.0	80.0	76.5
Perplexity (interpolated LMs)	70.2	67.6	67.9	66.7	66.5	65.9
Word error rate (interpolated LMs)	<b>14.24%</b>	14.02%	13.88%	13.81%	<b>13.75%</b>	<b>13.61%</b>

\* By resampling different random parts at the beginning of each epoch.